

# PROKASRO

## Product Catalogue



**ProKASRO Working Robots electric****8**

|   |       |
|---|-------|
| KASRO working robot 1.7 DN 130 – 400 / 5" - 16"                                 | p. 8  |
| KASRO working robot 4.0 DN 180 – 600 / 10" - 24"                                | p. 8  |
| KASRO working robot 3.5 DN 200 – 600 / 8" - 24"                                 | p. 9  |
| KASRO self-propelled unit DN 200 – 600 / 8" - 24"                               | p. 9  |
| <hr/>   |       |
| KASRO control unit electro  | p. 10 |
| KASRO control unit electro with spatula function                                | p. 10 |
| KASRO control unit electro in flightcase  | p. 11 |
| KASRO cable drum with 120 m / 393' electric twin cable                          | p. 12 |
| KASRO-Cable-Control-Unit CCU with 60 m / 80 m (196' - 262') electric twin cable | p. 12 |
| KASRO mobile cable drum with 150 m / 492' single cable                          | p. 13 |
| KASRO Cable-Control-Unit CCU with 110 m / 360' single cable                     | p. 13 |
| <hr/>   |       |
| Electro Converter-Kit   | p. 14 |
| Example of an electric conversion   | p. 15 |

**ProKASRO Working Robots pneumatic****18**

|   |       |
|---|-------|
| KASRO working robot 1.7 DN 130 – 400 / 5" - 16"                                   | p. 18 |
| KASRO working robot 4.0 DN 200 – 600 / 10" - 24"                                  | p. 18 |
| KASRO working robot 3.6 DN 200 – 600 / 8" - 24"                                   | p. 19 |
| KASRO self-propelled unit DN 200 – 600 / 8" - 24"                                 | p. 19 |
| <hr/>   |       |
| KASRO-Cable-Control-Unit CCU  | p. 20 |
| KASRO control unit  | p. 20 |
| KASRO mobile cable drum with 120 m / 393' twin cable                              | p. 21 |
| KASRO combination cable drum with 100 m or 140 m (328' or 459') combination cable | p. 21 |
| <hr/>   |       |
| KASRO mini swivel-head colour cameras   | p. 22 |

**ProKASRO Working Robots hydraulic****26**

|  |       |
|--|-------|
| KASRO hydraulic milling robot Goliath DN 250 - 600 / 10" - 24" | p. 26 |
| KASRO hydraulic milling robot Gretchen DN 150 - 250 / 6" - 10" | p. 26 |
| KASRO swivel-head colour camera with wiper                     | p. 27 |
| <hr/>  |       |
| KASRO hydraulic control unit                                   | p. 28 |
| KASRO hydraulic cable drum                                     | p. 28 |
| KASRO spatula cable drum                                       | p. 29 |

**ProKASRO CCTV system****30**

|   |       |
|---|-------|
| KASRO ProCAM CCTV inspection system DN 150 - 800 (6" - 32") cable version | p. 30 |
| KASRO ProLOOK CCTV inspection system DN 150 - DN 1000 (6" - 39") mobile   | p. 31 |

**ProKASRO Lateral Intake Rehabilitation****34**

|  |       |
|--|-------|
| KASRO injection sealing system DN 200 - 600 / 8" - 24" | p. 34 |
| KASRO cap placement system DN 150 - 600 / 6" - 24"     | p. 35 |
| <hr/>  |       |
| KASRO spatula robot DN 250 – 600 / 10" - 24"           | p. 36 |
| KASRO spatula robot DN 200 – 250 / 8" - 24"            | p. 36 |
| KASRO shield injection system DN 200 - 600 / 8" - 24"  | p. 37 |
| KASRO spatula accessories                              | p. 37 |

|   |       |
|---|-------|
| KASRO rotational module DN 200 - 600 / 8" - 24" | p. 38 |
| KASRO rotational module DN 150 - 400 / 6" - 16" | p. 38 |
| KASRO balloon placement attachment              | p. 39 |
| KASRO priming attachment                        | p. 39 |

## **ProKASRO UV-Technology 42**

|   |       |
|---|-------|
| KASRO UV CCU  | p. 42 |
| KASRO UV control unit PROFESSIONAL  | p. 42 |
| KASRO UV control in Flightcase  | p. 43 |
| KASRO UV curing drum PROFESSIONAL   | p. 43 |
| KASRO UV light source chain DN 150 - 500 / 6" - 20"                             | p. 44 |
| KASRO UV light core DN 550 - 1200 / 22" - 48"                                   | p. 44 |
| KASRO UV light core DN 1000 - 2000 / 39" - 80"                                  | p. 45 |
| Upgrades for KASRO POWER UV light sources                                       | p. 45 |
| KASRO UV JUMBO light core special wheel sets                                    | p. 46 |
| KASRO UV cameras  | p. 47 |
| KASRO UV packer set DN 150 - 500 / 6" - 20"                                     | p. 48 |
| KASRO UV packer set DN 600 - 800 / 24" - 32"                                    | p. 48 |
| KASRO UV packer set DN 1200 - 1600 / 48" - 63"                                  | p. 49 |
| KASRO UV packer set oval profile DN 400 / 600 - 1200 / 1800 (16"/24" - 48"/72") | p. 49 |
| KASRO UV packer set DN 1800 - 2000 / 71" - 80"                                  | p. 50 |
| Adapter for KASRO POWER UV light sources  | p. 50 |
| KASRO POWER UV control unit   | p. 51 |
| KASRO POWER UV curing drum  | p. 51 |
| KASRO UV manhole rehabilitation unit  | p. 52 |
| KASRO UV manhole rehabilitation packer DN 500 / 20"                             | p. 52 |
| KASRO UV manhole rehabilitation packer DN 600 / 24"                             | p. 53 |

## **ProKASRO bend capable 56**

|   |       |
|---|-------|
| KASRO UV light source chain system IKARUS | p. 56 |
|---|-------|

## **ProKASRO Rehabilitation Vehicles 58**

|   |       |
|---|-------|
| 3.5 t rehabilitation vehicle for KASRO electric working robots with battery pack            | p. 58 |
| 5 t rehabilitation vehicle for KASRO electric working robots with pull-out generator        | p. 59 |
| 5 t rehabilitation vehicle for KASRO electric working robots with accompanying trailer      | p. 60 |
| 6 t SUPERIOR rehabilitation vehicle with HYBRID drive for KASRO electric robots             | p. 61 |
| 14 - 18 t EXPERT rehabilitation vehicle for KASRO UV PROFESSIONAL                           | p. 62 |
| 14 - 18 t EXPERT rehabilitation vehicle for KASRO UV CCU                                    | p. 63 |
| 14 - 18 t EXPERT rehabilitation vehicle for KASRO POWER UV Technology                       | p. 64 |
| 12 - 18 t EXPERT rehabilitation vehicle for KASRO electric working robots                   | p. 66 |
| 12 - 18 t EXPERT rehabilitation vehicle for KASRO pneumatic working robots                  | p. 67 |
| 5 t rehabilitation vehicle for KASRO hydraulic working robots with trailer                  | p. 68 |
| KASRO 20"-Container - Example KASRO UV-Technology   | p. 69 |
| 14 - 18 t EXPERT 2.0 rehabilitation vehicle for KASRO UV technology                         | p. 70 |
| 12 - 18 t HYBRID rehabilitation vehicle for KASRO electric working robots for all functions | p. 71 |

# Technology that works for You

Intact sewer systems are an important part of urban infrastructures. Thus, the regular inspection and rehabilitation of the sewers have a correspondingly high importance. Our name stands for progressive sewer rehabilitation robotic systems - we develop tailor-made solutions for exactly such work. With our products many sewers can be restored to a first-class state. This is significantly easier and cheaper as placing new pipes. This secures the entire underground supply and thus maintains ecological, hygienic and technical standards.

Working Robots, Systems for Lateral Intake Rehabilitation, CCTV-Systems and UV-Technology; ProKASRO is a full-range supplier for sewer rehabilitation. We provide technology for damage diagnosis and repair in the ground without digging, traffic congestion or noise. Due to short completion times, a shot-off of the sewer is unnecessary. This ensures an efficient rehabilitation and a fast return back to the original state of the infrastructure.

The complete manufacturing of ProKASRO products takes place to up to 100 % in house: from the individual product idea up to the state of the art production. All components are produced and mounted internally. 100 % Made in Germany is an essential statement for ProKASRO.

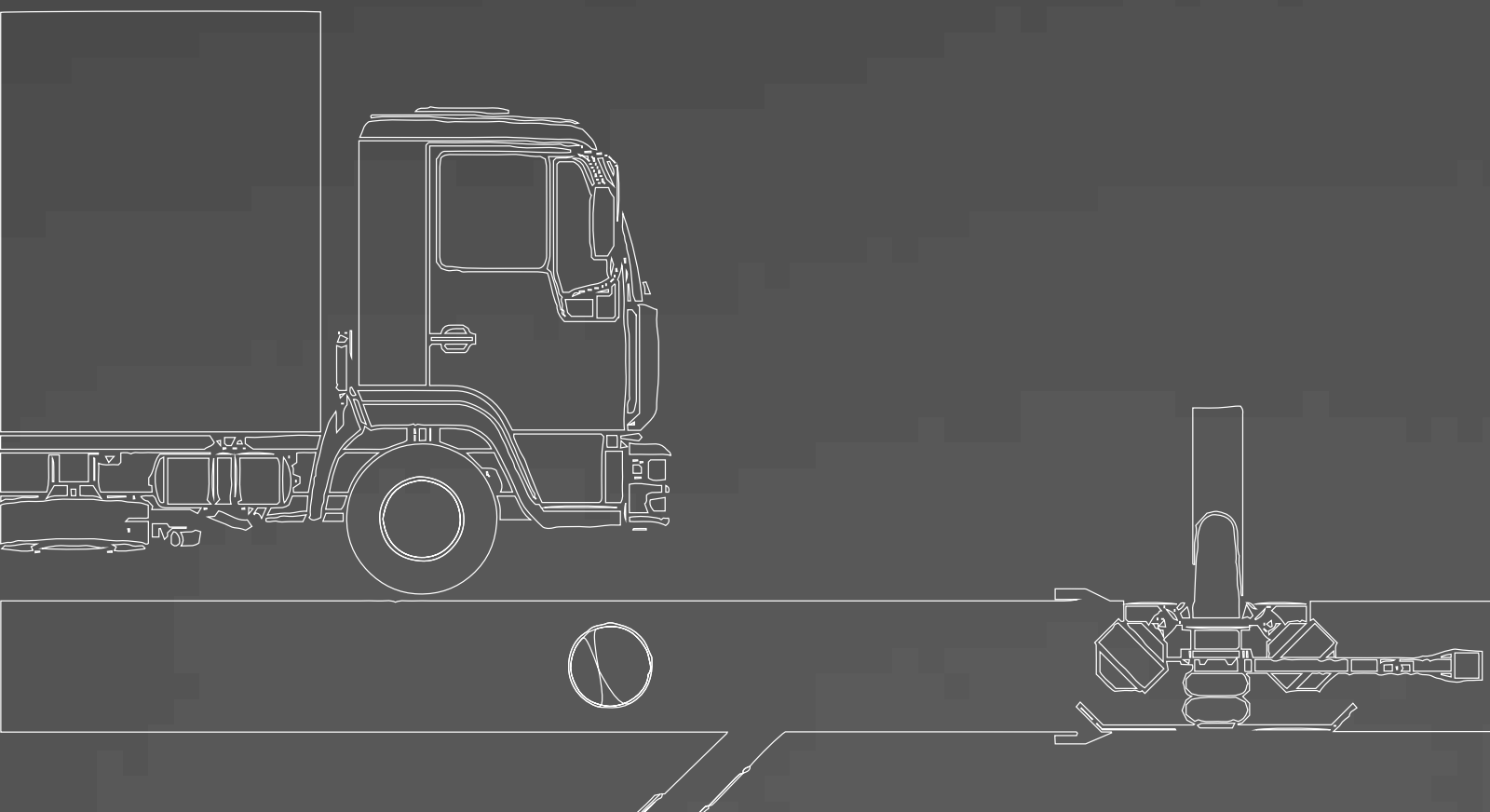



## Products

Our KASRO robot systems and systems for Lateral Intake Rehabilitation consist of individual components which are combinable among themselves. Any respectively desired rehabilitation solution can be accomplished. The rehabilitation work is controlled and monitored in the vehicles, equipped individually by us on request. Alternatively, this is possible by transportable mobile control units.

In the field of UV-Technology ProKASRO, is also diversified. We can cure your UV liners from DN 100 to DN 2000 (4" - 80") - partly mobile or in a rehabilitation vehicle.

## Service

ProKASRO is there for You - no matter where in the world you need us. We are on-site with our service technicians. In case you need our products only temporary, we have them ready for rental purposes. We bring our equipment to your construction site and show the performance of our products directly on-site. Of course we also train your employees.

A ProKASRO solution for sewer rehabilitation is an acquirement with sustainable and long-term benefit. We support you therefore also with financial opportunities. Please talk to us!

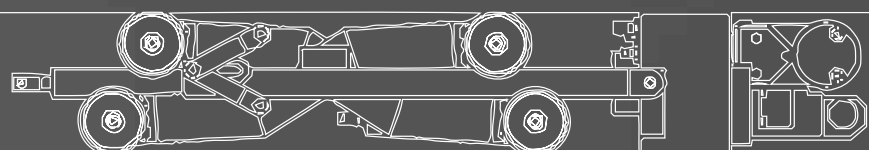

# ProKASRO Working Robots electric

The KASRO Working Robots are developed for rehabilitation work inside sewer pipes. Damage diagnoses and underground repair can be carried out for different pipe diameters from DN 100 up to DN 1200 (4'' - 47'') or even different profiles. Excavation work, unnecessary traffic obstructions and noise are avoided.

Various tool attachments permit the sewer robots to perform milling, grinding, filling, moulding and injection operations. Mainly obstacles such as misplaced pipe connectors, roots, encrustation and deposits, as well as opening connections after short pipe or inliner installation.

The single components are controlled by a suitable supply cable, depending on the model. The robots are driven in different ways - pneumatic, electric, hydraulic. The video signal of the camera is transmitted from the robot to the monitor in the workstation. Through that all action done by the robot can be observed and controlled on the monitor.

Some of the robots are driven by a multi-functional self-propelled unit.

Branch pipe joints of various sizes are rehabilitated through the KASRO injection sealing system and the KASRO cap placement system.





POWERLINE

# ProKASRO Working Robots electric

## KASRO working robot 1.7 DN 130 - 400 / 5" - 16"

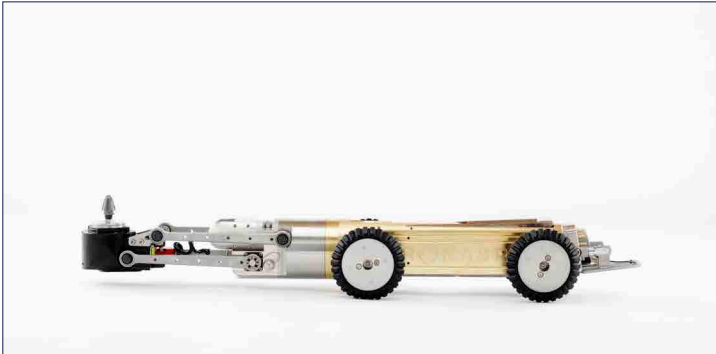

Article number: 3010018-E

- self-propelled working robot, 2000 W motor incl.
- with pressure monitoring **(significantly reduces repairs)**
- both driving axles are powered by independent electric motors
- all movements can be performed simultaneously

### Optional:

- various special wheelsets are available for difficult traction conditions (Article number: 3010020)
- egg-shaped-profiles to work in oval profiles DN200/300 (Article number: 3010017-EIPROFIL)
- 4th axis (Article number: AR175100)
- Motor: electric 2 kW (Article number: 1021438-E) suitable for KASRO working robots: 1.7, 1.9 also suitable for KASRO working robots 3.5, 3.6, 4.0
- 4th axis „Slim-Line“ (Article number: 3010010)
- Motor Power-Line 1200 W (Article number: 1021442-E) applicable from DN130 / 5"
- Recommendation for operation with twin cable for max. pulling force: self-propelled unit (1025150-E) and free-wheeling wheels (3010012)

| Technical Data  |   |
|-----------------|---|
| Dimensions      | Length without milling motor 650 mm / 26" + 140 mm / 6" swivelling connection, diameter 108 mm / 4" |
| Movements       | Rotation 540° (0-3 U/min), up/down 0-10 mm/s, drive 0-10 m/min                                      |
| Weight          | 25 kg / 55 lbs., with accessories 35 kg / 77 lbs.   |
| Operating media | 230 V   |
| Milling Motor   | electric 2 kW: 2000 W   |
| Tools           | Milling and grinding tools according to tool list, custom made products on request                  |

## KASRO working robot 4.0 DN 180 - 600 / 10" - 24"

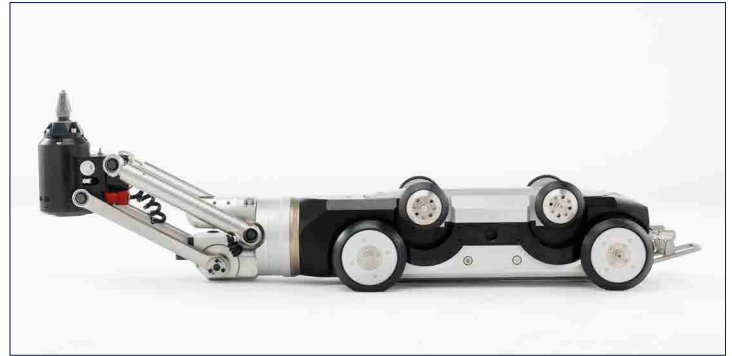

Article number: 1020011-E

- self-propelled working robot
- with pressure monitoring **(significantly reduces repairs)**
- all movements can be performed simultaneously
- milling in difficult geometries gets possible, e.g. a saddle of a pipe union
- the tool head can be tilted 90° in the direction of driving by means of the 4 th axis
- **NEW:** 4.0 \*New Generation\* working robot already applicable from **DN 180-600**

### Optional:

- expansion to DN 800 / 32" is possible (Article number: 1020003-Aufsatz)
- egg-shaped-profiles to work in oval profiles DN250/375 - DN500/750 (Art. #: 1020003-EI-PROFIL)
- Spare motor: electric 3 kW (Art. #: 1021435-E)
- Spare motor: electric 2 kW (Art. #: 1021438-E)

| Technical Data  |   |
|-----------------|---|
| Dimensions      | Length without milling motor 760 mm / 30", Width 134 mm / 5", Height 154 mm / 6"                                  |
| Movements       | Rotation 540° 0-2/min; Lift 250 mm / 10", 0 -10 mm/s; Swivel of tool head by 90°, drive (back/forward) 0-14 m/min |
| Weight          | 41 kg / 90 lbs., with accessories 98 kg / 216 lbs.  |
| Operating media | 230 V   |
| Milling Motors  | electric 3 kW: 3000 W<br>electric 2 kW: 2000 W  |
| Tools           | Milling and grinding tools according to tool list, custom made products on request                                |





## KASRO working robot 3.5 DN 200 - 600 / 10" - 24"

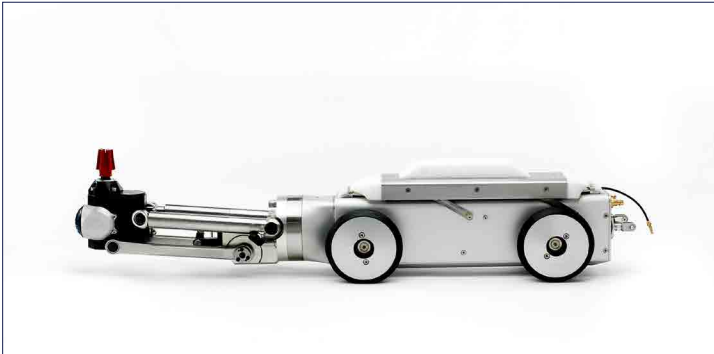

Article number: 1020000-E

- driven by a self-propelled unit
- basic frame can be mounted to the pipe wall by using air pads
- precision work is possible, in the same way like a milling machine
- tool head: see KASRO working robot 4.0
- 340° swivel colour camera with remote and close-up focus
- 2000 W and 3000 W motor inclusive

Optional:

- expansion to DN 800 is possible (Article number: 1029000)
- egg-shaped-profiles to work in oval profiles DN200/300, DN250/375, DN300/450, DN350/525, DN400/600, DN500/750 (Article number: 1027000)
- Spare motor: electric 3 kW (Article number: 1021435-E)
- Spare motor: electric 2 kW (Article number: 1021438-E) suitable for KASRO working robots: 3.5, 3.6, 4.0

| Technical Data  |  |
|-----------------|--|
| Dimensions      | Length 960 mm / 37", Width (without wheels) 92 mm / 4", Height 145 mm / 5"                                       |
| Movements       | Endless 540°, 0-2/min;<br>Feed 200 mm / 8", 0-10 mm/s;<br>Lift 250 mm / 10", 0-10 mm/s;<br>tilting tool head 90° |
| Weight          | 32 kg / 70 lbs., with carriage and camera 52 kg / 115 lbs.   |
| Operating media | 230 V  |
| Milling Motors  | electric 3 kW: 3000 W<br>electric 2 kW: 2000 W   |
| Milling tools   | Milling and grinding tools according to tool list, custom made products on request                               |

## KASRO self-propelled unit DN 200 - 600 / 10" - 24"

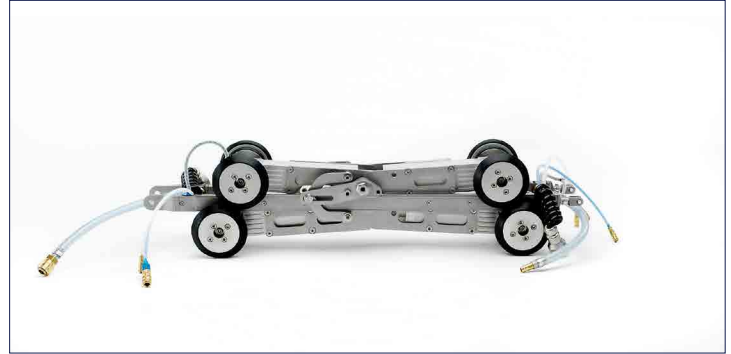

Article number: 1025100-E

- drive module for positioning purposes
- driven by four electric motors, one for each axis
- every axis is connected to the respective ends of a scissor-like chassis, that is spread by means of a compressed-air tension buffer
- this drive concept allows two axes to create tractive force in the sewer bed and two axes to create tractive force in the sewer peak
- simultaneously, this prevents that the driving axis is pressed into the box section when driving over disruptions or lateral branch connections
- the resilient retraction of the compressed-air tension buffer compensates for the sewer cross-section alterations

Also applicable as:

- independent drive module for KASRO injection sealing and cap placement system, for the priming attachment
- drive and positioning module for packers or for general transportation tasks

Optional:

- expansion to DN 800 / 32" is possible (Article number: 1029000)
- egg-shaped-profiles to work in oval profiles (Article number 1027005)

| Technical Data            |  |
|---------------------------|--|
| Dimensions                | Length 766 mm / 30", Width 130 mm / 5", Height 130 mm / 5" with wheels |
| Movements                 | All wheels are driven, driving speed 0-14 m/min                        |
| Weight                    | Drive unit 30 kg /66 lbs. base unit                                    |
| Operating media           | Compressed-air 8bar  |
| Traction and thrust force | 1000 N (Drive unit)  |

# ProKASRO Working Robots electric

## KASRO control unit electro



Article number: 1024350 / 1030002

- Control of the KASRO electric working robot using the extension for electric milling machines (Article number: 1030002)
- Can be integrated in vehicle or built as a mobile control station in a flight case
- Consists of a PLC-based control type for KASRO robots, a pneumatic unit and a monitor
- analog joysticks for robot functions
- Inclusive device for tele maintenance for diagnosis and maintenance of all network components and the control unit
- **Control of the drum speed possible via the control desk**

### Optional:

- Add-on of KASRO control unit with heating insert, necessary for all KASRO lateral intake systems (article number: 1024358)
- additional monitor 15", 17" or 24"

| Technical Data           |   |
|--------------------------|---|
| Dimensions control unit  | Length 500 mm / 20",<br>Width 1100 mm / 43",<br>Height 950 mm / 37" |
| Dimensions control panel | Length 250 mm / 10",<br>Width 550 mm / 22",<br>Height 260 mm / 10"  |
| Weight                   | 185 kg / 408 lbs.   |
| Operating voltage        | 230 V / 50 Hz / 10 A and<br>Heater module<br>230 V / 50 Hz / 6 A    |

## KASRO control unit electro with spatula function



Article number: 1024349

- Control of the KASRO electric working robot using the extension for electric milling machines
- Can be integrated in vehicle or built as a mobile control station in a flight case
- Consists of a PLC-based control type for KASRO robots, a pneumatic unit, a monitor and the KASRO control desk with the extension of spatula function with digital data transmission (BUS)
- Two joysticks serve as switches
- Inclusive device for tele maintenance for diagnosis and maintenance of all network components and the control unit
- **Control of the drum speed possible via the control desk**

### Optional:

- Add-on of KASRO control unit with heating insert, necessary for all KASRO lateral intake systems (article number: 1024358)
- additional monitor 15", 17" or 24"

| Technical Data           |   |
|--------------------------|---|
| Dimensions control unit  | Length 500 mm / 20",<br>Width 1100 mm / 43",<br>Height 950 mm / 37" |
| Dimensions control panel | Length 250 mm / 10", Width<br>550 mm / 22", Height 260<br>mm / 10"  |
| Weight                   | 185 kg / 408 lbs  |
| Operating voltage        | 230 V / 50 Hz / 10 A and<br>Heater module<br>230 V / 50 Hz / 6 A    |



## KASRO control unit electro in flightcase



Article number: 3010222

- **Ready-to-connect system for a safe worldwide transport without any problems**
- Flight Case for the KASRO control unit **with integrated insulation monitoring including insulation transformer**
- All components of this system are packed in separate Flightcases
- robots, wheel sets and further equipment can be packed and transported easily
- control unit within the Flightcase can be installed into a vehicle and can also be used mobile

|                |          |
|----------------|----------|
| Technical Data |          |
| Dimensions     | variable |
| Weight         | variable |

# ProKASRO Working Robots electric

KASRO cable drum  
with 120 m / 393' electric twin cable



Article number: 3010215-E / 3010213-E

- 120 m / 393' electric twin cable
- control and supply of the KASRO electric working robots for milling purposes
- two connected lines with a small cross-selection
- small compact alternative to the KASRO combination cable drum
- suitable for all spatula works (see „ProKASRO Lateral Intake Rehabilitation“, p.38)
- **incl. pressure and leakage monitoring, rotary feedthrough with compressed air channel and maintenance-friendly access (significantly reduces repairs)**
- Insulation monitoring including insulation transformer for KASRO electric robot systems for self-installation and for mobile usage (operator protection) (Article number: 3010223)

| Technical Data  |  |
|-----------------|--|
| Dimensions      | Length 800 mm / 32",<br>Width 540 mm / 22",<br>Height 790 mm / 31"     |
| Weight          | 280 kg / 617 lbs.  |
| Operating media | 230 V / 50 Hz / 10 A,<br>compressed-air 2,5 m <sup>3</sup> /min 12 bar |

KASRO-Cable-Control-Unit CCU with  
60m / 80 m (196' - 262') electric twin cable



Article number: 3010135 / 3010134

- mobile, compact, equipped with wheels to be installed in areas difficult to access
- control of the **electric** KASRO milling robot
- whole control system is installed above the hand-operated drum
- Consists of a PLC-based control type, electric control, monitor/control panel, data display, recording
- cable package consists of a combination cable with twin conductor
- manual cable drum with 60 m / 196' hose (Article number: 3010135)
- manual cable drum with 80 m hose / 262' (Article number: 3010134)
- Insulation monitoring including insulation transformer for KASRO electric robot systems for self-installation and for mobile usage (operator protection)
- cable guide optionally available (Article number: 3010131)

| Technical Data  |   |
|-----------------|---|
| Dimensions      | Length 750 mm / 30", Width 470 mm / 19", Height 920 mm / 36"            |
| Weight          | 220 kg / 236 kg / 485 lbs. / 520 lbs.                                   |
| Cable length    | 60 m / 80 m (196' - 262') cable combination                             |
| Operating media | 230 V / 50 Hz / 10 A;<br>compressed-air 2,5 m <sup>3</sup> /min, 12 bar |
| Water tank      | 12 l  |



## KASRO mobile cable drum with 150 m / 492' single cable



Article number: 3010214-E

- 150 m / 492' single cable
- control and supply of the KASRO working robot electric for milling purposes
- Camera cleaning and tool cooling is made through one single cable
- not suitable for lateral intake rehabilitation
- not compatible with KASRO electric working robot 3,5, 1.9
- **incl. pressure and leakage monitoring, rotary feedthrough with compressed air channel and maintenance-friendly access (significantly reduces repairs)**
- Insulation monitoring including insulation transformer for KASRO electric robot systems for self-installation and for mobile usage (operator protection)

| Technical Data  |   |
|-----------------|---|
| Dimensions      | Length 800 mm / 32",<br>Width 574 mm / 23",<br>Height 1010 mm / 39" |
| Weight          | 240 kg / 529 lbs.   |
| Operating media | 230 V / 50 Hz / 10 A  |

## KASRO-Cable-Control-Unit CCU with 110 m / 360' single cable



Article number: 3010137

- mobile, compact, equipped with wheels to be installed in areas difficult to access
- control of the **electric** KASRO milling robot
- whole control system is installed above the hand-operated drum
- Consists of a PLC-based control type, electric control, monitor/control panel, data display, recording
- with 110 m / 360' single cable
- not suitable for lateral intake rehabilitation
- Insulation monitoring including insulation transformer for KASRO electric robot systems for self-installation and for mobile usage (operator protection)
- cable guide optionally available (Article number: 3010131)

| Technical Data  |  |
|-----------------|--|
| Dimensions      | Length 750 mm / 30",<br>Width 470 mm / 19",<br>Height 920 mm / 36" |
| Weight          | 220 kg / 485 lbs.  |
| Cable length    | 110 m / 360'   |
| Operating media | 230 V / 50 Hz / 10 A   |
| Water tank      | 12 l   |

# ProKASRO Working Robots electric

## Electro Converter-Kit

### Now is the time to ensure **YOUR Converter-Kit** for the **KASRO** working robot

What does the Converter-Kit for the Electro-Robot contain?

- Pneumatic driven milling robot will be rebuild
  - New combination cable coupling with plug for the electric motor
  - **With pressure monitoring (significantly reduces repairs) and general overhaul** (except traction motor and housing)
- Cable drum TE 1.5 will be rebuild:
  - Drum conversion by expanding the rotary feedthrough and combination cable, as well as retrofitting the pressure monitoring
  - Convertible drum variants: TR2.0 / HT3.2 / TE1.5
- Control unit will be upgraded for the Electro-Robot (Article number: 1030002)

Optional:

- 400 V compressor can be removed
- Extension of the power supply via battery packs

**Notice:** Before each conversion, we have to check whether the conversion is possible!

Don't hesitate, make an appointment with us today for the conversion measure!

| <b>Advantages of converting from pneumatic to electric (Article number: 1030030-35)</b> |  |
|---|--|
| <b>high performance of the KASRO electric motor</b>                                     | <ul style="list-style-type: none"> <li>• highest efficiency during milling works</li> <li>• reduction of the rehabilitation time on-site</li> </ul>  |
| <b>space savings in regards to the rehabilitation vehicle</b>                           | <ul style="list-style-type: none"> <li>• smallest rehabilitation vehicle of 3.5 t</li> <li>• normal driver's license is sufficient</li> <li>• work procedure also in hard-to-reach areas possible</li> </ul> |
| <b>Advantages of upgrading with battery pack (Article number: 1030036)</b>              |  |
| <b>power supply via battery packs</b>   | <ul style="list-style-type: none"> <li>• performance is guaranteed for 14 hours</li> </ul>   |
| <b>minimal noise level</b>  | <ul style="list-style-type: none"> <li>• comfortable working atmosphere</li> <li>• milling works can be operated anytime without disturbing the general public</li> </ul>                                    |
| <b>environmental sustainability</b>   | minimising: <ul style="list-style-type: none"> <li>• CO2-emissions</li> <li>• Diesel consumption</li> <li>• pollution</li> </ul>   |



## Example of an electric conversion



Cable drum of the converted KASRO milling vehicle



Control unit of the converted KASRO milling vehicle

# ProKASRO Working Robots pneumatic







# ProKASRO Working Robots pneumatic

## KASRO working robot 1.7 DN 130 - 400 / 5" - 16"

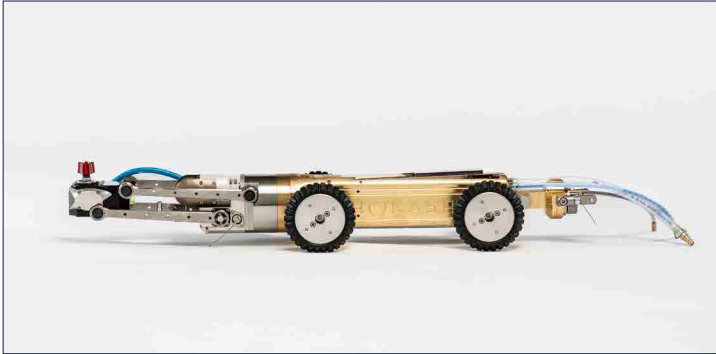

Article number: 3010018

- self-propelled working robot, 1200 W and 2500 W motor inclusive
- with pressure monitoring (**significantly reduces repairs**)
- both driving axles are powered by independent electric motors
- rotation 540°, so all movements can be performed simultaneously
- various special wheelsets are available for difficult traction conditions

### Optional:

- 4th axis (Article number: 1020009)
- high-traction wheelset (Article number: 3010020)
- 4th axis „Slim-Line“ (Article number: 3010010)
- egg-shaped-profiles to work in oval profiles DN200/300 (Article number: 3010017-EIPROFIL)

| Technical Data  |  |
|-----------------|--|
| Dimensions      | Length 950 mm / 37" + 140 mm / 6" swivelling connection, diameter 108 mm / 4"      |
| Movements       | Rotation 720° (0-3 U/min), up/down (0-10 mm/s), drive (0-10 m/min)                 |
| Weight          | 20 kg / 44 lbs. base unit  |
| Operating media | Compressed-air 12 bar, 2,5 m³/min (Compressor power)                               |
| Milling motor   | 1200 W (DN 150 / 6"); 2500 W (DN 200 – DN 400 / 8" - 16")                          |
| Milling tools   | Milling and grinding tools according to tool list, custom made products on request |

## KASRO working robot 4.0 DN 200 - 600 / 10" - 24"

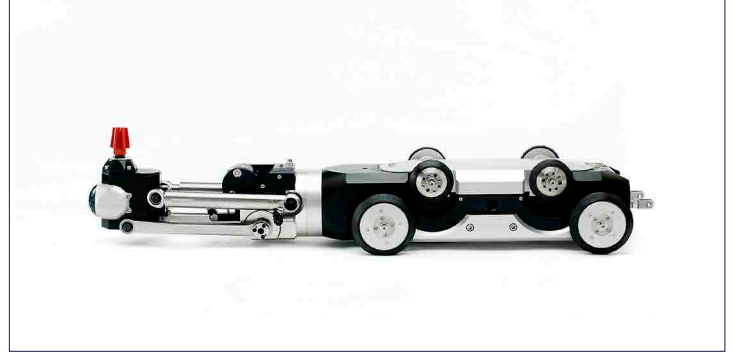

Article number: 1020011

- self-propelled working robot, 2500 W and 3600 W motor inclusive
- with pressure monitoring (**significantly reduces repairs**)
- milling by compressed-air motor 2500 W, 3600 W
- all movements can be performed simultaneously due to unlimited rotation
- milling in difficult geometries gets possible, e.g. a saddle of a pipe union
- the tool head can be tilted 90° by means of the 4th axis
- through that the milling motor can be equipped with longer extension shafts to work in smaller diameters

### Optional:

- expansion to DN 800 / 32" is possible (Article number: 1020003-Aufsatz)
- egg-shaped-profiles to work in oval profiles DN250/375 - DN500/750 (Article number: 1020003-EIPROFIL)

| Technical Data  |   |
|-----------------|---|
| Dimensions      | Length 1200 mm / 47", Width 134 mm / 5", Height 154 mm / 6"   |
| Movements       | Endless rotation 0-2/min; Lift 250 mm, 0 – 10 mm/s; Swivel of tool head by 90°, Drive (forward/backward) 0 – 14 m/min |
| Weight          | 36 kg / 79 lbs. base unit   |
| Operating media | Compressed-air 12 bar; 2,5 m³/min compressor power  |
| Milling Motor   | 3600 W compressed-air   |
| Milling tools   | Milling and grinding tools according to tool list, custom made products on request                                    |

## KASRO working robot 3.6 DN 200 - 600 / 8" - 24"

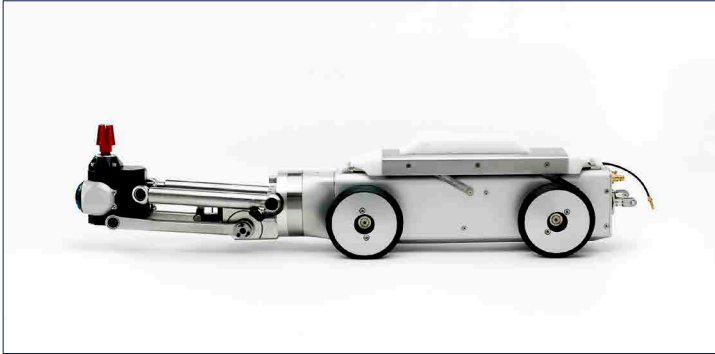

Article number: 1020002

- driven by a self-propelled unit, 3600 W motor incl.
- basic frame can be mounted to the pipe wall by using air pads
- precision work is possible, in the same way like a milling machine
- tool head: see KASRO working robot 4.0
- 340° swivel colour camera with remote and close-up focus

### Optional:

- expansion to DN 800 / 32" is possible
- egg-shaped-profiles to work in oval profiles (Article number: 1027000)
- DN200/300, DN250/375, DN300/450, DN350/525, DN400/600, DN500/750

| Technical Data  |   |
|-----------------|---|
| Dimensions      | Length 960 mm / 37",<br>Width (without wheels) 92mm / 4",<br>Height 145 mm / 6"                           |
| Movements       | Endless rotation, 0-2/min;<br>Feed 200 mm, 0-10 mm/s;<br>Lift 250 mm, 0-10 mm/s;<br>tilting tool head 90° |
| Weight          | 32 kg / 70 lbs., with carriage and camera 52 kg / 115 lbs.  |
| Operating media | Compressed-air 12 bar, 2,5 m <sup>3</sup> /min (Compressor power)   |
| Milling Motor   | 3600 W / 2500 W compressed-air  |
| Milling tools   | Milling and grinding tools according to tool list, custom made products on request                        |

## KASRO self-propelled unit DN 200 - 600 / 8" - 24"

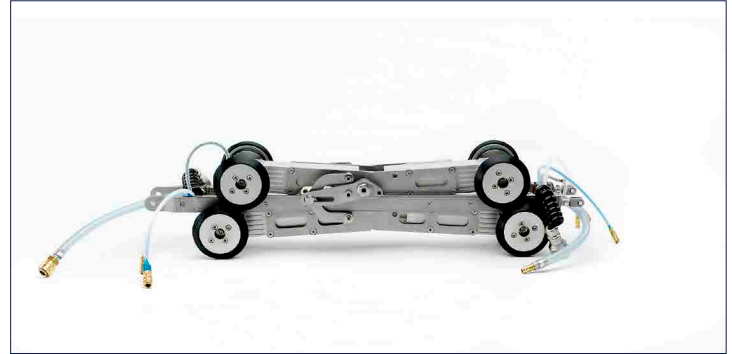

Article number: 1025100

- drive module for positioning purposes
- driven by four electric motors, one for each axis
- every axis is connected to the respective ends of a scissor-like chassis, that is spread by means of a compressed-air tension buffer
- this drive concept allows two axes to create tractive force in the sewer bed and two axes to create tractive force in the sewer peak
- simultaneously, this prevents that the driving axis is pressed into the box section when driving over disruptions or lateral branch connections
- the resilient retraction of the compressed-air tension buffer compensates for the sewer cross-section alterations

### Also applicable as:

- independent drive module for KASRO injection sealing and cap placement system, for the priming attachment
- drive and positioning module for packers or for general transportation tasks

### Optional:

- expansion to DN 800 / 32" is possible (Article number: 1029000)
- egg-shaped-profiles to work in oval profiles (Article number 1027005)

| Technical Data            |   |
|---------------------------|---|
| Dimensions                | Length 766 mm / 30", Width 130 mm / 5",<br>Height 130 mm / 5" with wheels |
| Movements                 | All wheels are driven,<br>driving speed 0-14 m/min                        |
| Weight                    | Drive unit 30 kg /66 lbs. base unit                                       |
| Operating media           | Compressed-air 8bar   |
| Traction and thrust force | 1000 N (Drive unit)   |

# ProKASRO Control Units and Cable Drums

## KASRO-Cable-Control-Unit CCU



Article number: 3010130

- mobile, compact, equipped with wheels to be installed in areas difficult to access
- control of all KASRO **air-milling robots** and **lateral intake systems**
- whole control system is installed above the hand-operated drum
- Consists of a PLC-based control type, pneumatic control, monitor/control panel, data display, recording
- cable package consists of a combination cable with twin conductor

| Technical Data  |   |
|-----------------|---|
| Dimensions      | Length 750 mm / 30",<br>Width 470 mm / 19",<br>Height 920 mm / 36"      |
| Weight          | 190 kg / 419 lbs.   |
| Cable length    | 60 m / 196' cable combination (expandable up to 80 m / 262')            |
| Operating media | 230 V / 50 Hz / 10 A;<br>compressed-air 2,5 m <sup>3</sup> /min, 12 bar |
| Water tank      | 12 l  |

## KASRO control unit



Article number: 1024350

- Control of the KASRO electric working robot using the extension for electric milling machines (Article number: 1030002)
- Can be integrated in vehicle or built as a mobile control station in a flight case
- Consists of a PLC-based control type for KASRO robots, a pneumatic unit, a monitor and the KASRO control desk with the extension of spatula function with digital data transmission (BUS)
- Two joysticks serve as switches
- Inclusive device for tele maintenance via remote control
- **Control of the drum speed possible via the control desk**

### Optional:

- Add-on of KASRO control unit with heating insert, necessary for all KASRO lateral intake systems (article number: 1024358)
- additional monitor 15", 17" or 24"

| Technical Data           |   |
|--------------------------|---|
| Dimensions control unit  | Length 500 mm / 20",<br>Width 1100 mm / 43",<br>Height 950 mm / 37" |
| Dimensions control panel | Length 250 mm, Width 550 mm, Height 260 mm                          |
| Weight                   | 185 kg / 408 lbs.   |
| Operating voltage        | 230 V / 50 Hz / 10 A and<br>Heater module<br>230 V / 50 Hz / 6 A    |

### KASRO mobile cable drum with 120 m / 393' twin cable

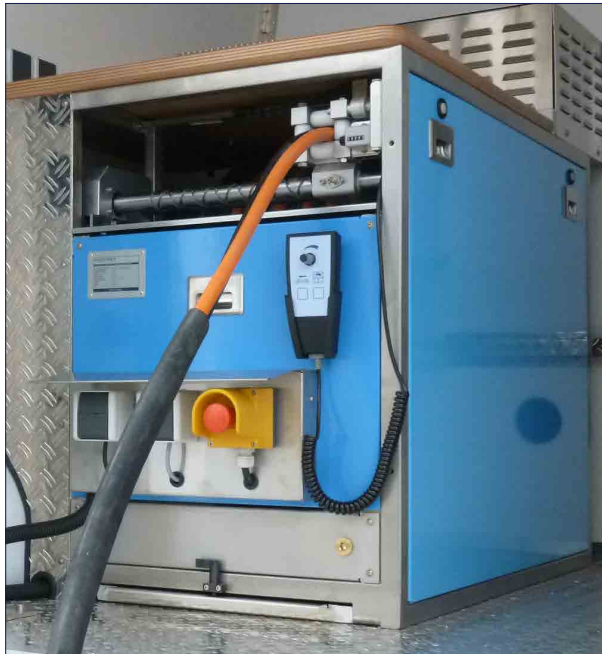

Article number: 3010211

- 120 m / 393' twin cable
- control and supply of the KASRO working robot pneumatic for milling purposes and the lateral connection systems
- small compact alternative to the KASRO combination cable drum
- suitable for all spatula works (see „ProKASRO Working Robots hydraulic“, p.24)

| Technical Data  |  |
|-----------------|--|
| Dimensions      | Length 800 mm / 32",<br>Width 540 mm / 22",<br>Height 790 mm / 31"     |
| Weight          | 290 kg / 639 lbs.  |
| Operating media | 230 V / 50 Hz / 10 A,<br>compressed-air 2,5 m <sup>3</sup> /min 12 bar |

### KASRO combination cable drum with 100 m or 140 m / 328' or 459' combination cable



Article number: 6021110 / 6021111

- control and supply of all pneumatic KASRO working robots
- Systems for Lateral Intake Rehabilitation
- KASRO spatula robots and the shield injection system
- combination cable contains all lines: power lines, control air lines, water line

Available with:

- 100 m / 328' combination cable (ø 40 mm)
- optional: bigger version with 140 m / 459' combination cable (ø 40 mm)

| Technical Data  |  |
|-----------------|--|
| Dimensions      | Length 1800 mm / 72",<br>Width 680 mm / 27",<br>Height 1220 mm / 48" |
| Weight          | 500 kg / 1102 lbs.   |
| Operating media | 230 V / 50 Hz / 10 A   |
| Outer sheath    | PUR Kevlar reinforced  |

# ProKASRO Working Robots pneumatic

## KASRO mini swivel-head colour cameras



Article number 1024308

### halogen camera 3.5:

- suitable for KASRO working robot 3.6 and 4.0
- halogen lighting
- larger chassis, positioned on the side
- special feature: focus drive

#### Option:

- Additional lighting for HALOGEN camera for self-installation for KASRO working robots from DN 400 / 16" (Article number: 1024306)



Article number: 1024307

### LED camera 4.6: **SELF-CLEANING**

- suitable for all robots
- LED lightning
- smaller chassis, therefore more suitable for smaller pipe diameters
- camera is self-cleaning because the glass cylinder rotates separately to the lens

#### Option:

- Additional lighting for LED camera for self-installation for KASRO working robots from DN 400 / 16" (Article number: 1024305)

Both cameras are equipped with a rotary drive, hence every desired picture can be observed

| Technical Data |   |   |
|----------------|---|---|
|                | Halogen camera  | LED camera  |
| Dimensions     | Length 136 mm / 5"<br>Chassis cross-section 87 mm / 3"<br>Swivel-head diameter 70 mm / 3" | Length 120 mm / 5"<br>Chassis cross-section 66 mm / 2,5"<br>Swivel-head diameter 45 mm / 2" |
| Movements      | Swivel 340°, focus up to 10 mm  |   |
| CCD camera     | 625 lines   |   |
| Objective      | 53,4°   |   |



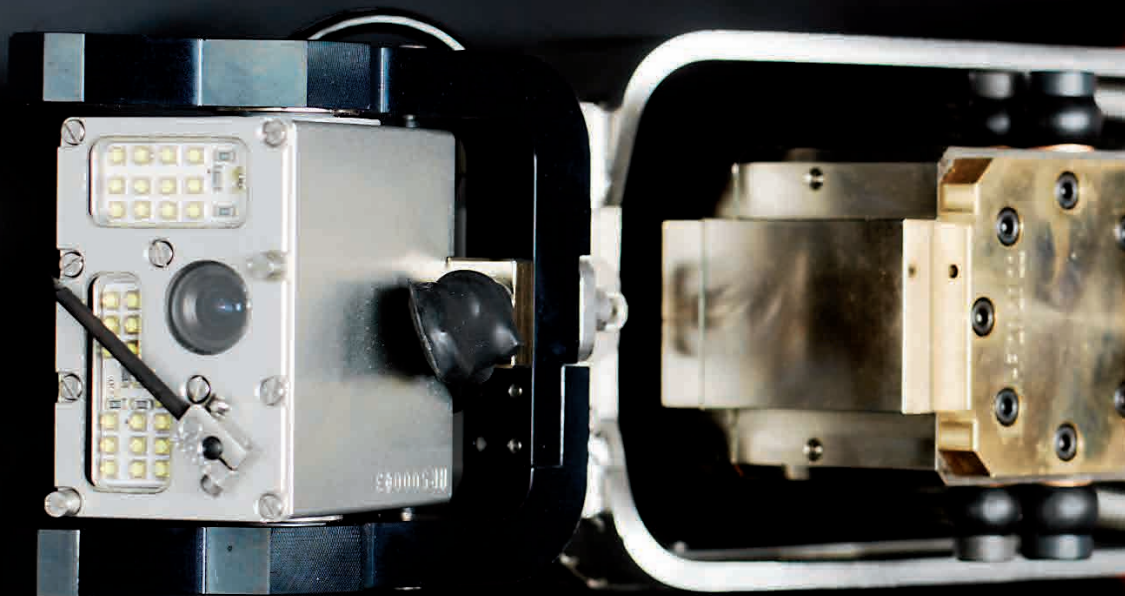



# ProKASRO Working Robots hydraulic

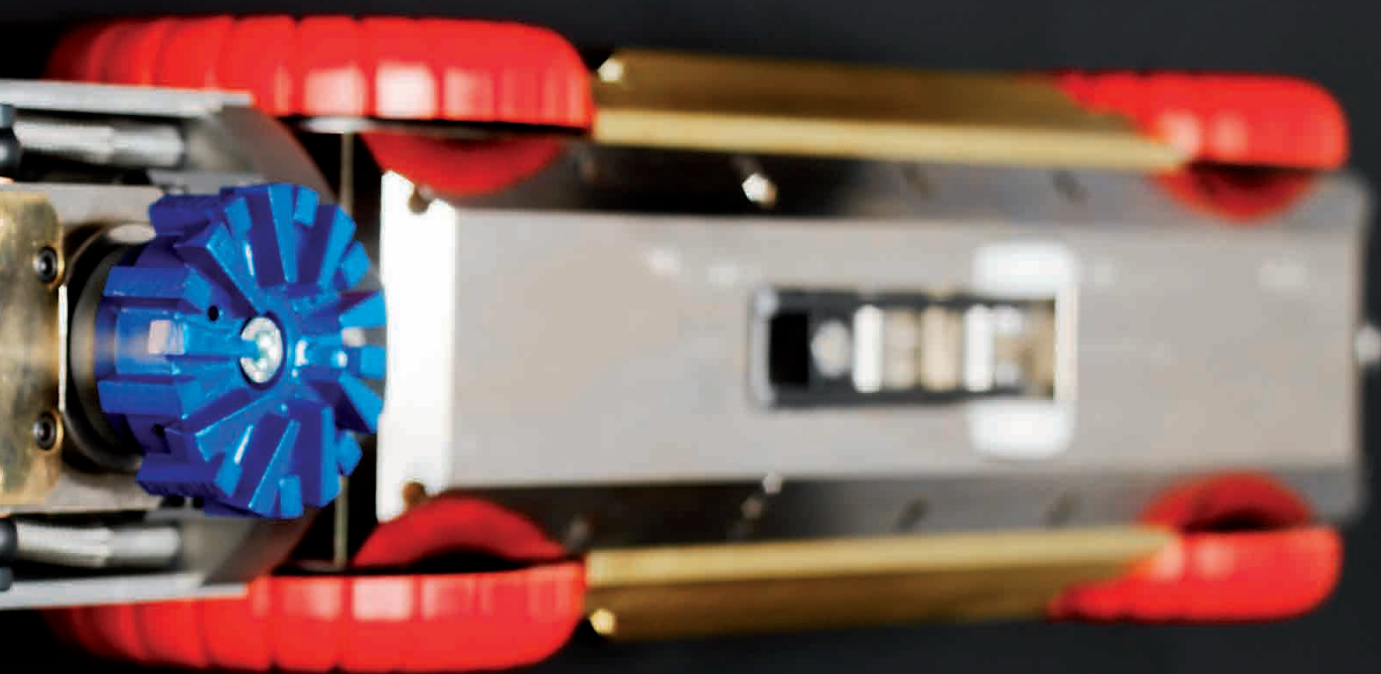

# ProKASRO Working Robots hydraulic

## KASRO Hydraulic milling robot GOLIATH DN 250 - 600 / 10" - 24"

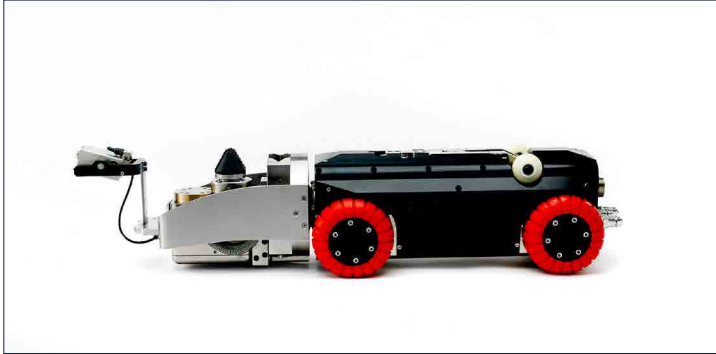

Article number: 5010001

- self-propelled working robot
- electrical and hydraulic powered
- axial movement is performed by the drive unit
- inclusive KASRO miniature pan-head camera with wiper for hydraulic robot

### Optional

- Adaptation to DN 800 / 32" is possible (Article number: 5010051)
- Oval profile attachment module to work in oval profiles DN300/450 / 12"/18" and DN600/900 24"/ 35" (Article number: 5010020)

## KASRO Hydraulic milling robot GRETCHEN DN 150 – 250 / 6" - 10"

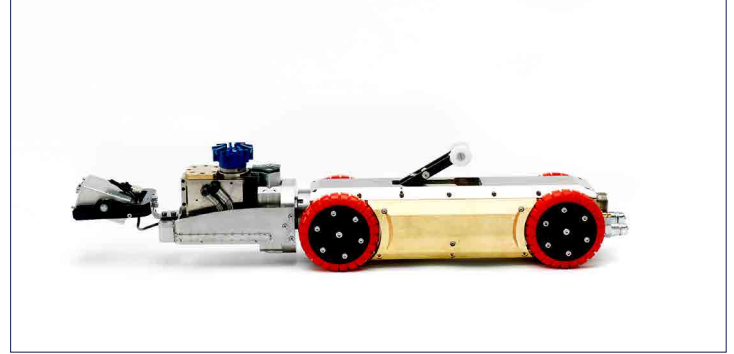

Article number: 5010002

- self-propelled working robot
- energy supply results from electrical and hydraulic energy
- axial movement is performed by the drive unit
- inclusive KASRO miniature pan-head camera with wiper for hydraulic roboter

### Optional

- Oval profile attachment module to work in oval profiles DN 200/300 / 8" / 12" and DN 250/375 10" / 15" (Article number: 5010025)

| Technical Data  |  |
|-----------------|--|
| Dimensions      | Length 830 mm / 32",<br>Width 210 mm / 8",<br>Height 190 mm / 8" |
| Driving speed   | 0–12 m/min   |
| Movements       | Rotation 900°, Lift 110 mm / 4"                                  |
| Weight          | 80 kg / 176 lbs.   |
| Operating Media | Oil pressure 150 bar   |
| Motor           | 5 kW at 3500–4500 1/min<br>milling motor                         |

| Technical Data  |  |
|-----------------|--|
| Dimensions      | Length 740 mm / 30",<br>Width 130 mm / 5",<br>Height 112 mm / 4" |
| Driving speed   | 0–12 m/min   |
| Movements       | Rotation ca. 900°, Lift 65 mm / 2,5"                             |
| Weight          | 45 kg / 99 lbs.  |
| Operating media | Oil pressure 150 bar   |
| Motor           | 3,5 kW bei 5000–6000 1/min<br>milling motor                      |



## KASRO swivel-head colour camera with wiper



Article number: 5014300

- to be mounted on hydraulic driven milling robots
- swivel forward to observe the run-in movement
- swivel backward to observe the milling
- fixed focus
- numerous LEDs around the camera lens ensure sufficient illumination
- wiper in front of the camera lens guarantees an optimal camera image

| Technical Data  |   |
|-----------------|---|
| Dimensions      | Length 122 mm / 5",<br>Width 96 mm / 4",<br>Height 42 mm / 2" |
| Movements       | Swivel 300°   |
| Operating media | 12 V  |
| Camera          | 625 TV lines  |
| Objective       | 78°   |

# ProKASRO Working Robots hydraulic

## KASRO hydraulic control unit



Article number 1024370

- KASRO base control unit for hydraulic milling robots
- to be installed in hydraulic rehabilitation vehicles with control panel and 15"-TFT-monitors
- Inclusive device for tele maintenance via remote control

Expandable with:

- KASRO spatula control unit (Article number: 1024369)
- KASRO injection-air control unit (Article number: 1024372)

| Technical Data           |  |
|--------------------------|--|
| Dimensions control unit  | Length 500 mm / 20",<br>Width 580 mm / 23",<br>Height 780 mm / 31" |
| Dimensions control panel | Length 290 mm / 12",<br>Width 550 mm / 22",<br>Height 170 mm / 7"  |
| Weight                   | 105 kg / 232 lbs.  |
| Operating media          | 230 V / 50 Hz / 10 A   |

## KASRO hydraulic cable drum



Article number 6031110

- control and supply of the hydraulic milling robots
- installed in the vehicle
- 100 m / 328' hose packet
- consistant of:
  - three hydraulic lines  $\varnothing$  12 mm / 0,5"
  - one electric cable with integrated water line
- robots can be retracted out of the sewer pipe

| Technical Data                     |   |
|------------------------------------|---|
| Dimensions                         | Length 2000 mm / 79",<br>Width 800 mm / 32",<br>Height 1450 mm / 57"                                    |
| Weight                             | 630 kg / 1389 lbs.  |
| Operating media                    | 230 V / 50 Hz / 10 A  |
| Combination cable                  | 3 x HD-hose 12 mm,<br>1 x PUR-hose 8 x 12 mm<br>22 x 0,75 mm <sup>2</sup> , 2 x 2 x 0,5 mm <sup>2</sup> |
| Outer sheath PUR Kevlar reinforced |   |



## KASRO spatula cable drum



Article number 6031111

- Extension to the hydraulic cable drum
- 100 m / 328' spatula cable

| Technical Data    |  |
|-------------------|--|
| Dimensions        | Length 800 mm / 32",<br>Width 540 mm / 22",<br>Height 790 mm / 32"                   |
| Weight            | 190 kg / 419 lbs.  |
| Operating media   | 230 V / 50 Hz / 10 A   |
| Combination cable | 1 x PUR-hose 8 x 12 mm<br>22 x 0,75 mm <sup>2</sup> ,<br>2 x 2 x 0,5 mm <sup>2</sup> |

# ProKASRO CCTV system

KASRO ProCAM CCTV inspection system DN150 – DN800 (6"-32") cable version



Article number: 4050150

## Camera:

- High-resolution CCD color camera KZ95CB (2.38 mil. Pixels, 2x 120 ° swivel range, 360 ° rotation) and wheel sets from DN150
- Camera equipped with LED light and additional LED ring lighting
- Compatible with all ProCAM push cameras and ProLook crawler DN150 - DN1000

## Trolley

- Camera trolley BOSS135 4x4 with connection for additional light, manual pantograph and hook for easy and safe lowering to a shaft
- manual lifting arm (pantograph)
- speed control for crawler

## Control unit

- control case PC 110/230 V AC, 15" color monitor
- Integrated PC with software equipment
- DigiCAN LIGHT sewerage software enables various information (data, time, cable length, inclination, rotation, component printing) to be inserted and images and videos to be created on suspicious areas
- Video logging and data overlay

## Cable drum

- 200m / 656' automatic cable drum,
- Including cable remote control HANDCONTROL as control unit for manual monitoring of the winding process of the cable in the cable drum and the lifting device; with integrated display

| Technical Data Camera |   |
|-----------------------|---|
| Dimensions            | Length: 170 mm / 7"<br>Diameter: 90 mm / 4"                               |
| Weight                | 1,5 kg / 3l bs.   |
| Movements             | Viewing angle 50°, 2 x 120°<br>Pivotable, 360° rotation                   |
| Lighting              | 24 high power LEDs  |
| Colour CCD camera     | Resolution PAL 720x576TVL<br>CVBS,<br>10x optical zoom + 12x digital zoom |
| Cable                 | 200m / 656'   |

| Technical Data Trolley |  |
|------------------------|--|
| Dimensions             | Length 390 mm / 15",<br>Width 90 mm / 4" |
| Weight                 | 12,7 kg / 28 lbs.                        |
| Motor                  | 75 W                                     |
| Diameters              | DN 150 up to DN 800 / 6"-32"             |



## KASRO ProLOOK CCTV inspection system DN 150 to DN 1000 (6" - 39") mobile



Article number: 4050060-MOBIL

### Camera

- colour CCD camera KZ 95CB
- aluminium housing with IP68 protection
- pressure resistant up to 1 bar
- efficient and fully reliable
- measuring unit for permanent ovality measuring during CCTV
- integrated laser to measure cracks, pipe irregularities and pipe offsets

### Control unit

- mounted in a robust case
- available installed in a rack or mobile in a case
- 15" LCD monitor, control desk and data logging inclusive

- Software Digi-CAN Light
- two joysticks serve as switches
- includes all control elements for sewer inspection
- compatible with the KASRO working robot

### Trolley

- 6 x 6 all-wheel drive
- function of self stabilization
- pressure acquisition up to 1 bar
- compatible with KZ90CB / KZ95CB camera head
- integrated rear view camera
- additional lighting 18xLED 17,5W / 2274 lm
- transmitter sonde for 33 kHz and 512 Hz
- hooks for save insertion in the manhole

### Cable drum

- Automatic motor driven cable reel
- Guiding roll for cable relief
- Meter counter for the length measurement of the coiled-off cable.
- 200m / 656' cable (500m / 1640' as an option)

| Technical Data Camera |   |
|-----------------------|---|
| Dimensions            | Length: 173 mm / 7"<br>Diameter: 90 mm / 4"               |
| Weight                | 2,1 kg / 4,6 lbs.   |
| Movements             | tilting 2 x 120° and rotating 360° endless                |
| Lighting              | 24x High Power LED  |
| Colour CCD camera     | 2,38 mil. pixels<br>10 x optical zoom + 12 x digital zoom |
| Cable                 | 200 m / 656' up to max. 500 m / 1640'                     |

| Technical Data Trolley |  |
|------------------------|--|
| Dimensions             | Length 420 mm / 17",<br>Width 83 mm / 3" |
| Weight                 | 12,7 kg / 28 lbs.                        |
| Motor                  | 2 x 100 W                                |
| Diameters              | DN 150 up to DN 1000 / 6"-39"            |

# ProKASRO Lateral Intake Rehabilitation

The KASRO lateral intake rehabilitation systems were especially developed for lateral intake rehabilitation of different sizes. They will be positioned with the help of the self-propelled unit, a rotational module and a camera.

The injection sealing system with epoxy resin carries the injection material directly in membrane cartridges. The material's flow path is very short and can be injected into the damage spot quickly. The material hardens immediately.

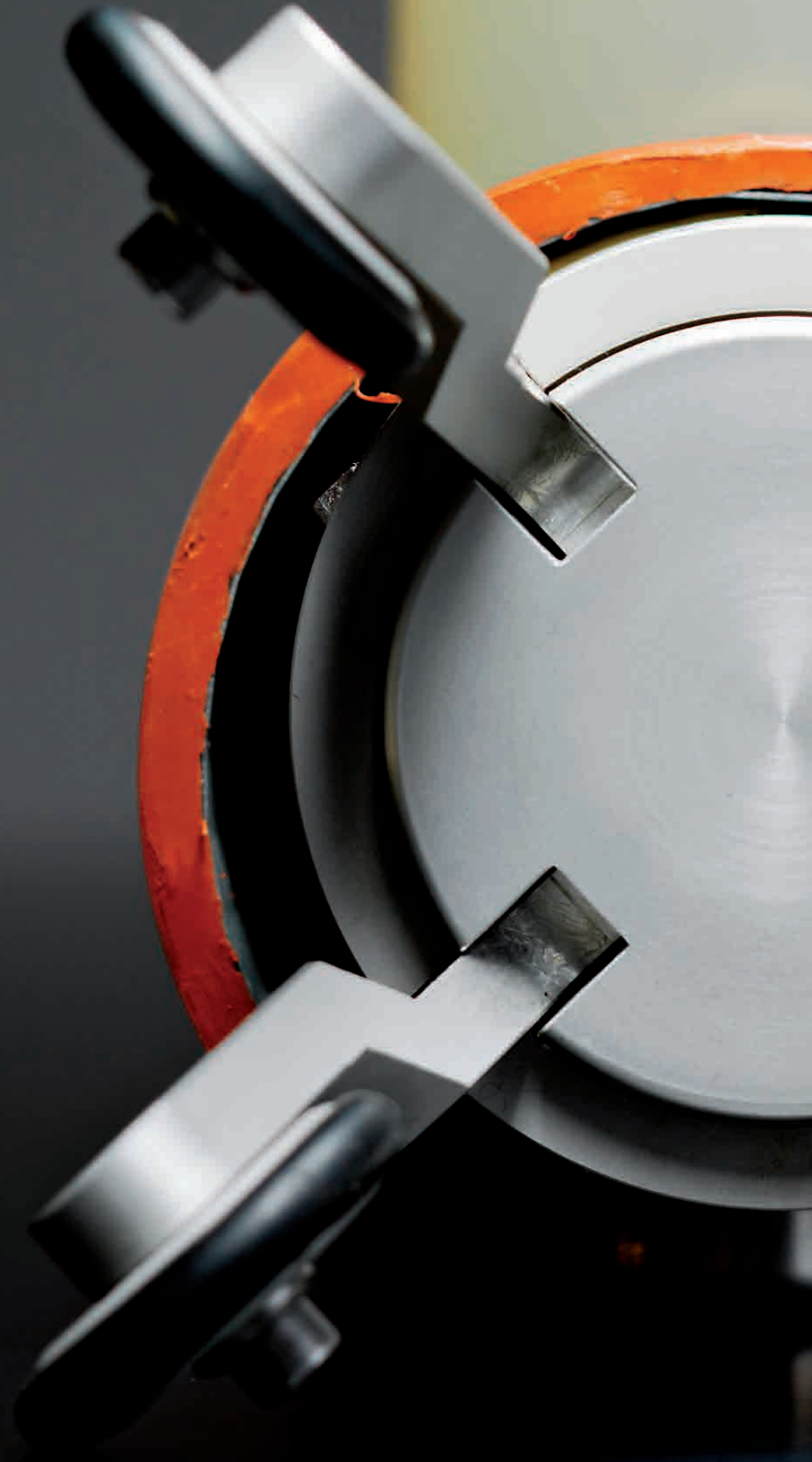





KASRO cap placement system rehabilitates lateral intakes via laminated caps. The caps are impregnated with epoxy resin. They are being inserted in short hats and put over long hats (1m). The curing process will be accelerated by a form plate and a balloon heating.

# ProKASRO Lateral Intake Rehabilitation

KASRO injection sealing system  
DN 200 - 600 / 8" - 24"

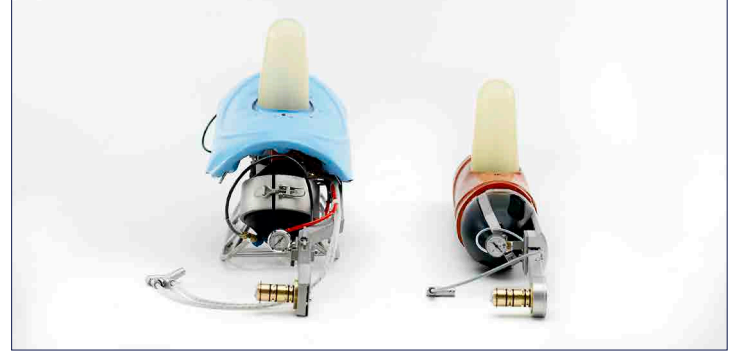
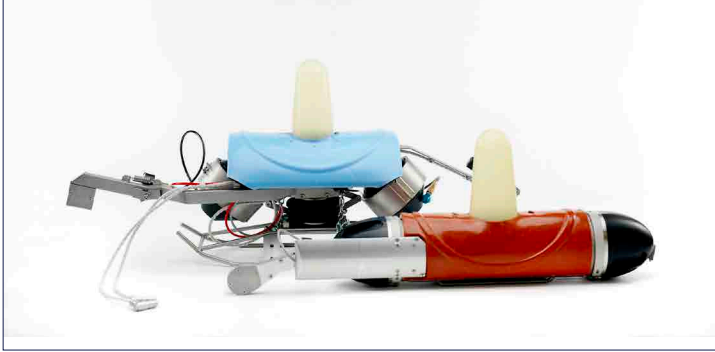

Article number: 1023101

- for rehabilitation of lateral intakes
- with epoxy resin (other material possible)
- injection material is carried within membrane cartridges underneath the form plates
- the pressure of the injection is directly transferred to the damage spot
- the intersection angles and axes are not predetermined due to a side balloon and a collapsible seal on the form plate, which are fully expandable and inflatable with compressed air
- the side balloon can be sucked back behind the form plate
- the electric heating of the balloon and the form plate support the curing of the applied sealing materials
- KASRO camera change box for three cameras which show the user how the branch pipe looks like and how far the material is pressed in

| Technical Data                         |   |
|--|---|
| Dimensions<br>DN200 / 8"               | Length 716 mm / 29" (without holding arm), chassis diameter 150 mm / 6", Weight 25 kg / 55 lbs.                                       |
| Dimensions<br>DN250-600 /<br>10" - 24" | Length 550 mm / 22" (without holding arm), Weight 15 kg / 33 lbs.   |
| Flat compressing shield                | 400 mm x 360 mm / 16" x 14"   |
| Dimensions<br>balloon                  | Base diameter 100 mm, Height 203 mm / 8" (short conical balloon), 233 mm / 9" (long conical balloon), 350 mm / 14" (cylinder balloon) |
| Heating                                | Shield 250 W, balloon 200 W or 300 W  |
| Cartridge size                         | DN 200 / DN 250 (8"/10"): 2 x 1,5 liters<br>from DN 300 / 12": 2 x 2,1 liters   |



## KASRO cap placement system DN 150 - 600 / 6" - 24"



Article number: 1023120



Article number: 1023122

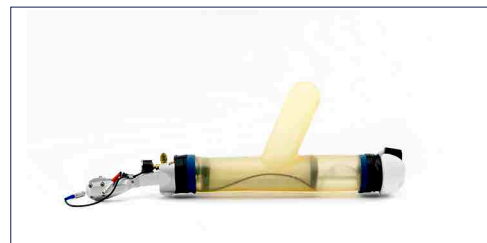

Article number: 1023121

- the intersection angles and axes are not predetermined due to a side balloon and a collapsible seal on the form plate, which are fully expandable and inflatable with compressed air.
- to ensure an easy and non-destructive procedure of the cap placement system in the main sewer, the form plate is inclined to the back and the diameter of the entire device is reduced by means of a compressed air cylinder
- the electric heating of the balloon and the form plate reduce the reaction time of the used resins and adhesives
- the heating energy also reaches the upper areas of the balloon further in the lateral intake
- the various flexible form plates ensure that they optimally adjust to every pipe diameter

| Technical Data                               |  |
|--|--|
| Cap placement system DN 150 / 6"             |  |
| Dimensions                                   | Length (with holding arm) 840 mm / 33", diameter 120 mm / 5"               |
| Length cap                                   | 150 mm / 6"  |
| Weight                                       | 5 kg / 11 lbs.   |
| Heating                                      | 300 W, shield and balloon  |
| Special feature                              | available with front camera  |
| Cap placement system DN 200 - 600 / 8" - 24" |  |
| Dimensions DN 200 / 8"                       | Length 580 mm / 23" (without holding arm), 725 mm / 29" (with holding arm) |
| Dimensions DN 250 - 600 / 10" - 24"          | Length 675 mm / 26" (without holding arm), 917 mm / 36" (with holding arm) |
| Weight                                       | 15 kg / 33 lbs.  |
| Surface shield                               | 400 mm x 360 mm / 16" x 15"  |
| Dimensions balloon                           | Base diameter 100 mm / 4", Length 350 mm / 15"                             |
| Heating                                      | Shield 250 W, balloon 300 W  |
| Height cap                                   | 300 mm / 12"   |
| Material for cap                             | Epoxy resin (standard)   |

# ProKASRO Lateral Intake Rehabilitation

KASRO spatula robot  
DN 250 - 600 / 10" - 24"



Article number: 5010050/ 5010050-B

KASRO spatula robot  
DN 200 - 250 / 8" - 10"



Article number: 5010060/ 5010060-B

- self-propelled working robot in each diameters
- premixed resin is pressed out a canister by compressed-air to be processed
- seal cracks, fractures, joints or holes
- spatula accessories are inclusive (article number: 9020041/9020042)
- moves the scraper device to and from the pipe wall via two separately controllable arms
- powered via a 100 m / 328' combination cable, consisting of air and electric lines
- the tool head can rotate and the lateral movement is controlled via the drive unit
- Receptacle for a disposable material socket

Optional:

- Upgrade for reusable containers as well as different resin mixers sold separately
- Reusable material container 2.3 l and 3.5 l for KASRO spatula robot self-propelled for DN 250 - 600 / 10" - 24" (Article number: 5010061)
- Reusable material container 1 l and 1.8 l for KASRO spatula robot self-propelled for DN 200 - 250 / 8" - 10" (Article number: 5010062)

| Technical Data  |   |   |
|-----------------|---|---|
|                 | DN 250 - 600 / 10" - 24"  | DN 200 - 250 / 8" - 10"                                       |
| Dimensions      | Length 1000 mm / 39"<br>Width 230 mm / 9"<br>Height 190 mm / 8" | Length 800 mm / 32"<br>Width 95 mm / 4"<br>Height 103 mm / 4" |
| Driving speed   | 0-10 m/min  |   |
| Movements       | Rotation 900°<br>Lift: 80 mm / 3"                               | Rotation 900°<br>Lift: 65 mm / 2"                             |
| Weight          | 75 kg / 165 lbs.  | 50 kg / 110 lbs.  |
| Operating media | 42V DC, compressed-air 8 bar, 1000 l/min                        |   |
| Tools           | for axial, radial and hole filling, balloon placement           |   |
| Material        | Epoxy resin (standard)  |   |



## KASRO shield injection system DN 200 - 600 / 8" - 24"

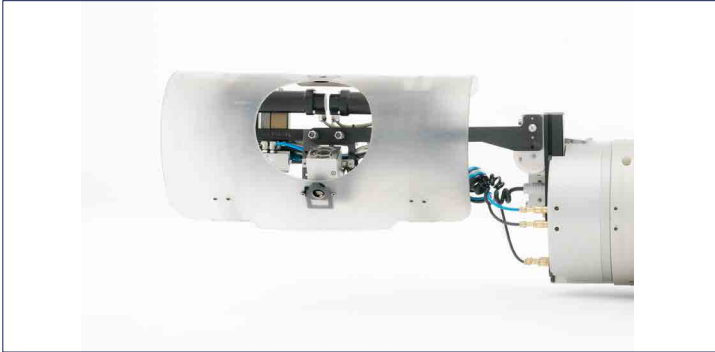

Article number: 5010055 shield injection system

## KASRO spatula accessories

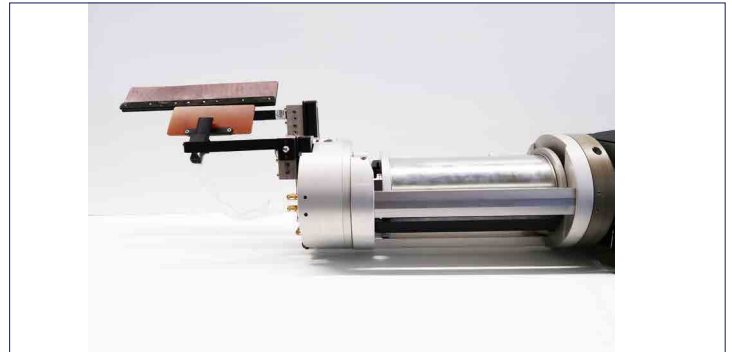

Article number: 9020041/ 9020042



Article number: 5010080  
KASRO swivel-head colour camera  
to control the spatula process



The shield injection system device can be mounted on:

- the KASRO spatula robot DN 150 - 300 / 6" - 12"
- the KASRO spatula robot DN 300 - 600 / 12" - 24"
- also possible: up to DN 800 / 32" and oval profile
- the devices carry a material cartridge (disposable or refillable) with the premixed material
- it is pressed out by a compressed-air cylinder
- the spatula device seals cracks, fractures, joints or holes
- move the scraper device to and from the pipe wall via two separately controllable arms
- the tool head can rotate and the lateral movement is controlled via the drive unit
- with the shield injection system the material can be pressed into the transition area between the lateral intake and the main sewer

| Technical Data |                                   |
|----------------|-----------------------------------|
| Dimensions     | Length 480 mm / 19"               |
| Movements      | Rotation 540°<br>Lift: 65 mm / 2" |
| Weight         | 3,6 kg / 8 lbs.                   |

# ProKASRO Lateral Intake Rehabilitation

## KASRO rotational module DN 200 - 600 / 8" - 24"



Article number 1025110

The KASRO rotation module is mounted to the front of the drive unit to use the equipment for the lateral intake equipment

Available for:

- DN 200 - 600 / 8" - 24" to be mounted on the KASRO self-propelled unit DN 200 - 600 / 8" - 24"
- install of the KASRO mini swivel-head colour camera possible

## KASRO rotational module DN 150 - 400 / 6" - 16"



Article number: 1025111

The KASRO rotation module is mounted to the front of the drive unit to use the equipment for the lateral intake equipment

Available for:

- DN 150 - 400 / 6" - 16" to be mounted on the KASRO self-propelled unit DN 150 / 6"
- install of the KASRO mini swivel-head colour camera possible

| Technical Data |  |
|----------------|--|
| Dimensions     | Length 265 mm / 11",<br>diameter 145 mm / 6" |
| Weight         | 5,7 kg / 13 lbs.                             |

| Technical Data |  |
|----------------|--|
| Dimensions     | Length 264,5 mm / 11",<br>diameter 130 mm / 5" |
| Weight         | 4,6 kg / 10 lbs.                               |

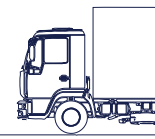

## KASRO balloon placement attachment



Article number: 1022100

- placement of pipe sealing plugs
- with compressed-air it can be extended up to two levels to position the pipe sealing plug into the pipe connections
- due to the assembly of the holding rings the 1st and the 2nd level can be blocked, esp. important for small diameters
- mounted on the KASRO working robot instead of the KASRO compressed-air motor

| Technical Data  |  |
|---|--|
| Dimensions  | Length 100 mm / 4",<br>Width 69 mm / 3",<br>Height 160 mm / 6" |
| Weight  | 2,2 kg / 5 lbs.  |
| Extension length level 1                                      | 69 mm / 3"   |
| Extension length level 2                                      | 134 mm / 5"  |
| suitable for football balloons<br>other adapters upon request |  |

## KASRO priming attachment

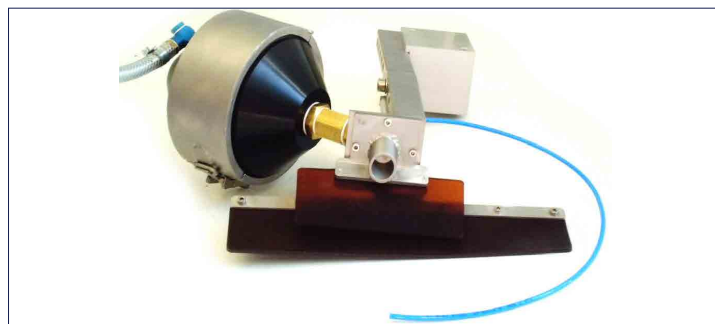

Article number: 1023200

- sealing of cracks in the sewer wall and collars
- scraper applies the priming material to the leak, a second trailing scraper spreads the material smoothly
- mounted on the KASRO working robot instead of the KASRO compressed-air motor, cartridge with the priming material is simply screwed on
- form plates from DN 200 - 600 / 8" - 24"

| Technical Data   |   |
|------------------|---|
| Dimensions       | Length 180 mm / 7",<br>Width 137 mm / 6",<br>Height 176 mm / 7" (without cartridge) |
| Weight           | 4,3 kg / 9 lbs.   |
| Cartridge volume | 1 l (2 l possible for larger diameters)   |

# ProKASRO UV-Technology

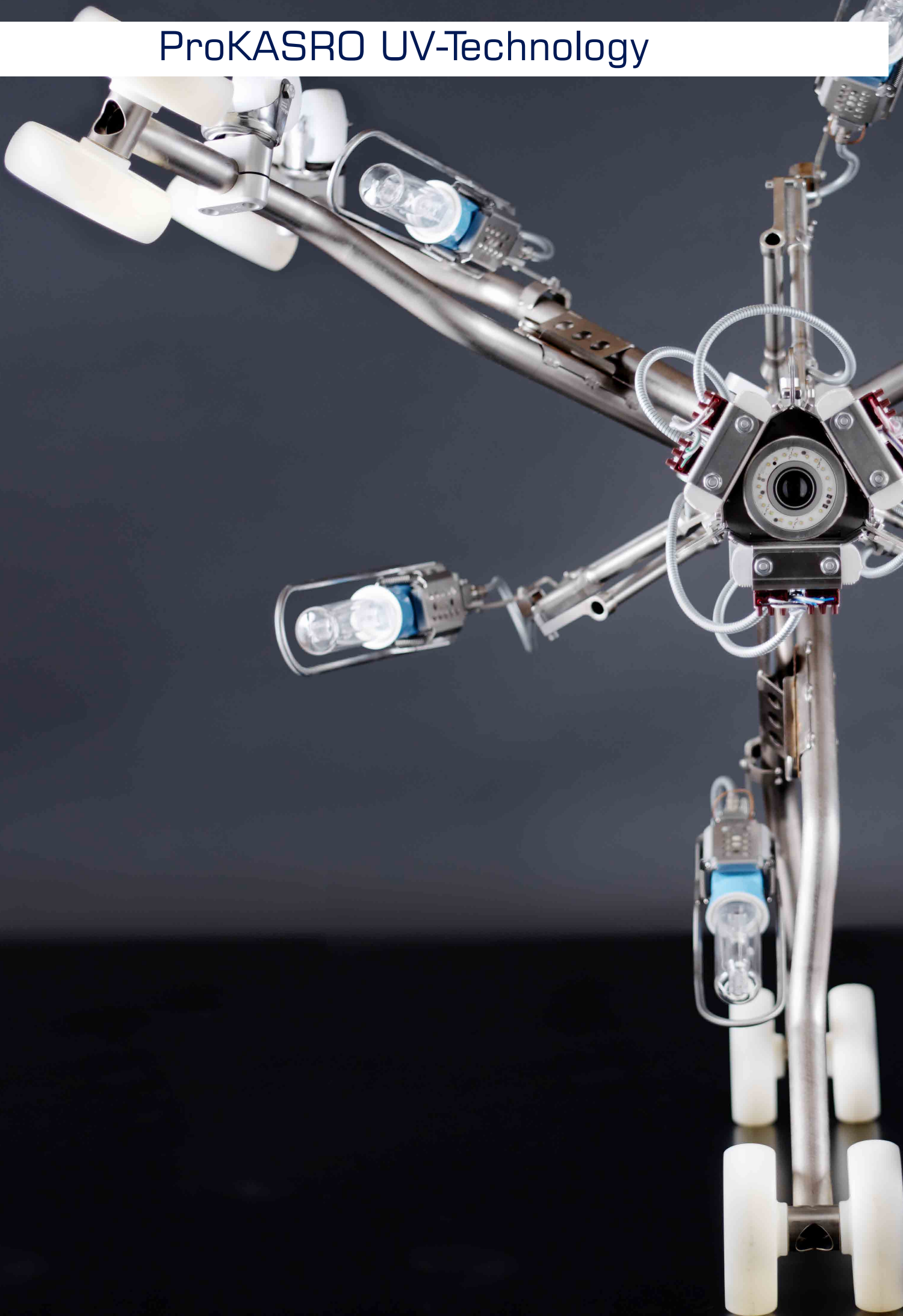





To operate the installation of CIPP pipe liners in an efficient manner we produce KASRO UV curing systems since 2003. The use of specially designed UV lamps and their shadow free positioning on the UV light core facilitates trouble free liner installations in the sewer from DN 100 up to DN 2000 (4" - "). The process is monitored by the operator via the heat resistant pluggable camera located within the UV light core. Infra red sensors positioned on the UV light core transmit laminate curing temperatures to the operator.

The innovative KASRO UV-Technology provides curing times which set new standard with up to 36.000 W. The new construction of the KASRO cores creates the qualification to cure pipe liners beyond diameters of DN 2000 / 80" in an efficient and secure way.

# ProKASRO UV-Technology

## KASRO UV CCU



Article number: 4020004

- DN 150 to DN 1200 / 6" - 47"
- 200-240 m / 656' - 787' curing cable
- mobile, compact, equipped with four wheels, rehabilitation can be operated within the narrowest streets
- complete control unit above electric driven cable drum
- operation, display, datalogging via 21" Touchscreen PC
- can be installed in a vehicle
- Inclusive device for tele maintenance via remote control
- control of the KASRO light sources:
  - 8 x 400 W
  - 8 x 600 W
  - 8 x 1000 W
- inclusive Adapter for the connection of light sources with 12 x 1000 W technic with 8 x 1000 W units (max. 8-Lamps)

| Technical Data |   |
|----------------|---|
| Dimensions     | Depth 142 cm / 56" + 88 cm / 34"<br>Length 70 cm / 28"<br>Height 160 cm / 63" |
| Weight         | 530 kg / 1168 lbs.  |
| Length cable   | 200 - 240 m / 656' - 787'   |
| Diameters      | DN 150 - DN 1200 / 6" - 47"   |

## KASRO UV control unit PROFESSIONAL



Article number: 4020019

- with adapter for power supply 8 x 400 Watt / 600W / 1000W as well as for 12 x 1000 W light source DN 1600 / 63" (automatic switch between the respective UV light sources possible)
- display and recording of the camera image
- WIN TV for video files recording including PC
- entire datalogging of the curing process
- operation is performed using a touch-screen monitor on which all important data is displayed graphically, all measuring data can easily be monitored
- all data and misfunctions can be saved on a PC
- the resulting datalogging of the curing process can be printed after the rehabilitation
- Inclusive device for tele maintenance via remote control

| Technical Data          |  |
|-------------------------|--|
| Dimensions control unit | Length 500 mm / 20",<br>Width 1650 mm / 65",<br>Height 1535 mm / 60" |
| Weight                  | 250 kg / 551 lbs.  |
| Operation voltage       | 400 V / 50 Hz / 64 A   |

## KASRO UV control in Flightcase



Article number: 4020082

- **Ready-to-connect system for a safe worldwide transport without any problems**
- All components of this system are packed in separate Flightcases
- UV light trains, wheel sets and further equipment can be packed and transported easily
- control unit within the Flightcase can be installed into a vehicle and can also be used mobile

| Technical Data |          |
|----------------|----------|
| Dimensions     | variable |
| Weight         | variable |

## KASRO UV curing drum PROFESSIONAL



Article number: 4020000 / 4020003

- 200-300 m / 656'-984' curing cable cooling system integrated
- installed version in the truck
- due to the mechanical freewheel the cable can easily be removed
- equipped with a screen and control display, to be able to control and monitor the light chain from the drum
- the light chain in the sewer pipe is retracted with the preset speed using the UV curing cable drum
- the speed adjustment ensures that the prescribed curing time is exactly met and logged

| Technical Data  |  |
|-----------------|--|
| Dimensions      | Length 1580 mm / 62",<br>without swivel arm 1160 mm / 45",<br>Width 700 mm / 28",<br>Height 1300 mm / 51"  |
| Weight          | 570 kg / 1257 lbs.   |
| Operating media | 400 V / 50 Hz  |
| Curing cable    | UV and heat resistant self netting PUR outer sheath, Kevlar reinforced<br>5 x 2 x 0.25 mm <sup>2</sup> Teflon isolated,<br>10 x 0.6 mm <sup>2</sup> , 24 x 1.5 mm <sup>2</sup> ,<br>1x Teflon coax |

# ProKASRO UV-Technology

## KASRO UV light source chain DN 150 - 500 / 6" - 20"



Article number: 4020050 / 4020051 / 40200502

- 8 x 400 W, 8 x 600 W (4020050)
- 9 x 400W, 9 x 600 W (4020051)
- Extension of existing KASRO UV light source chain 400/600 W to 12 x 400/600 W (40200502)
- with the respective wheel extension the light chain can be adjusted to the rehabilitating diameter
- can also be enlarged to oval profile for DN 300 / DN 450 (12"/18") to DN 400 / DN 600 (16"/24")
- 16 "crosses" are mounted on the circular enclosure of the individual elements of the light train

### Optional:

- Extension of existing KASRO UV light source chain 400/600 W (4020050, 4020051) to 12 x 400/600 W consisting of:
- KASRO light source chain 3 or 4 x 400/600 W pluggable with UV bulbs and wheel sets (without camera mounting)

| Technical Data |  |
|----------------|--|
| Dimensions     | Length approx.. 3300 mm / 118", pluggable wheel extensions         |
| Performance    | 8 UV-lamps à 400 W pluggable in ceramic frame                      |
| Sensors        | 3 piece variable IR sensors for recording the laminate temperature |

## KASRO UV light core DN 550 - 1200 / 22" - 48"

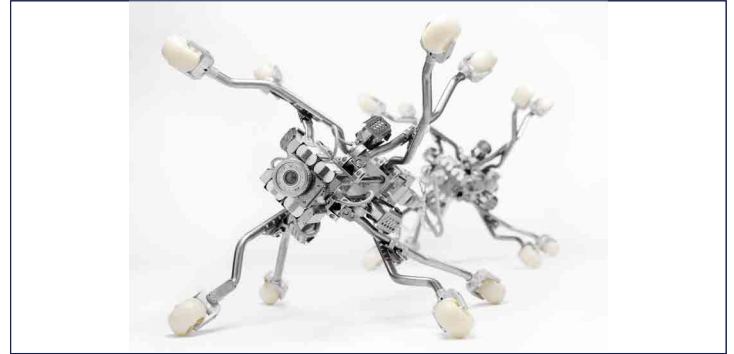

Article number: 4020070/ 4020074

- 2 x 4 x 1000 W (Article number: 4020070)
- 3 x 4 x 1000 W (Article number: 4020074)
- centralisation of the light core within the sewer is achieved by electric motors altering the expansion which is observed by a camera within the packer
- the centralisation process is monitored by the operator via the UV and heat resistant pluggable camera located within the UV light core
- automatic shutdown prevents over expansion of the UV light core once the preset diameter is reached
- to reduce curing times, three UV light cores can be connected together by using of specially designed wheelsets
- expansion of the lamp performance to 12.000 W is possible
- for oval profiles
  - DN 500 / DN 750 (20"/30")
  - DN 600 / DN 900 (24"/35")
  - DN 800 / DN 1200 (32"/48")
- the two bottom feet are changed by longer feet
- therefore sufficient UV light is emitted to the bottom part of the liner

| Technical Data          |   |
|-------------------------|---|
| Dimensions              | Retracted diameter 360 mm / 14", Length 970 mm / 38"                                  |
| Diameters               | DN 550 - 1200 / 22" - 48"   |
| Weight                  | 25 kg / 55 lbs. each core   |
| Centralisation          | electric  |
| Power                   | 4 UV lamps, 1000 W each, pluggable in ceramic frame                                   |
| Dimensions oval profile | Heigth min 320 mm / 13", max 925 mm / 36"<br>Width min 300 mm / 12", max 610 mm / 24" |

## KASRO UV light core DN 1000 - 2000 / 39" - 80"

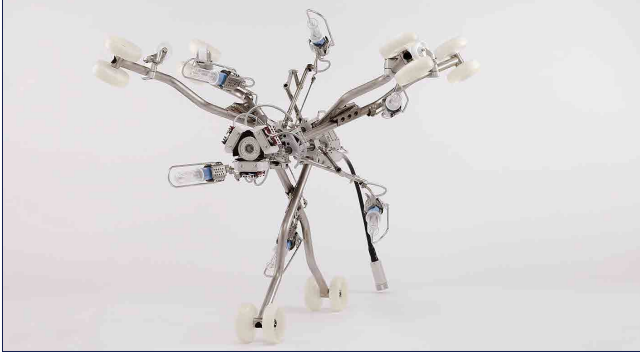

Article number: 4020085

- 2 x 6 x 1000 W
- for oval profiles
  - DN 800 / DN 1200 (32" - 48")
  - DN 900 / DN 1350 (35" - 53")
- to reduce curing times up to 3 UV light cores can be connected
- expansion of the lamp performance to 18.000 W is possible
- for oval profiles
  - DN 800 / DN 1200 (32" - 37")
  - DN 900 / DN 1350 (35" - 53")
- the two bottom feet are changed by longer feet
- therefore sufficient UV light is emitted to the bottom part of the liner

## Upgrades for KASRO POWER UV light sources



Article number: 4020205/ 4020208 + 4020235  
4020223/ 4020233/

- 3 x 6 x 1000 W / 2000 W
- 4 x 4 x 1000 W / 2000 W
- 12 x 400 W / 600 W
- 15 x 400 W / 600 W
- expansion of the lamp performance to 36.000 W is possible
- all POWER UV light sources can be operated by any KASRO UV PROFESSIONAL or KASRO UV CCU system by using a special adapter (p. 50 - Article number: 4020222 / 4020220)

| Technical Data |  |
|----------------|--|
| Dimensions     | Length with wheels: 1250mm / 49"<br>Length without wheels: 1100 mm / 43" |
| Diameters      | DN 1000 - 2000 / 39" - 80"   |
| Diameter       | closed core: 560mm / 22"<br>maximum diameter: 1600mm / 63"               |
| Wheight        | 30 kg / 66 lbs.  |
| Power          | 6 x 1000 W   |

| Technical Data |                          |
|----------------|--------------------------|
| Diameters      | DN 150 - 2000 / 6" - 80" |
| Power          | up to 36.000 W           |

# ProKASRO UV-Technology Accessories

## KASRO UV JUMBO light core Special wheel sets



Article number: 4020267

- Ball wheel set for KASRO UV JUMBO core
- set consisting of 4 pieces (4 are needed per core)
- optimal curing of liners in special profiles without leaving marks

## KASRO UV JUMBO light core Special wheel arm sets



Article number: 4020234

- Additional extensions for KASRO Jumbo light source core PROFESSIONAL and POWER UV for circular profiles DN1600 - DN2000 / 63" - 90"
- Set of 4 pieces (+ two egg profile wheel extensions required from standard equipment that means 6 pieces per core)

### Technical Data

|             |                      |
|-------------|----------------------|
| Dimensions  | Diameter 200 mm / 8" |
| Ball wheels |                      |

### Technical Data

|                |                     |
|----------------|---------------------|
| Dimensions     | Length 520 mm / 20" |
| Arm extensions | Width 220 mm / 9"   |
|                | Height 170 mm / 7"  |

## KASRO UV camera



Article number: 4020080

- heat-resistant
- can be mounted to any KASRO UV light source
- illumination via an LED lighting ring
- with colored picture

| Technical Data  |  |
|-----------------|--|
| Dimensions      | Length 105 mm / 4",<br>chassis diameter front 80 mm / 3",<br>chassis diameter plug side 50 mm / 2" |
| Operating media | 30 V / 12 V  |

## KASRO UV backeye cameras



Art. #: 4020096 / 4020211; 4020095 / 4020210

- KASRO Back-Eye camera for mounting on KASRO UV light source cores from DN550 to DN1600 for KASRO UV PROFESSIONAL systems (Article number: 4020096)
- KASRO Back-Eye camera for KASRO POWER UV system 12 - 18 x 1000 W; Mountable at KASRO UV light cores DN550 - DN2000 (Article number: 4020211); not compatible with KASRO UV PROFESSIONAL
- back and front visibility
- KASRO Back-Eye-camera inclusive connector module to mount to curing connector for all KASRO UV light sources (except KASRO POWER-UV) (Article number: 4020095)
- KASRO Back-Eye camera for KASRO POWER system 12 - 18 x 1000 W mountable on UV light sources 8 x 400 W/ 600 W and 2 x 6 x 1000 W; not compatible with KASRO UV PROFESSIONAL (Article number: 4020210)
- with connector module mountable at the connector (cable side)
- applicable from DN 300 / 12"
- back and front visibility

| Technical Data                     |   |
|------------------------------------|---|
| Dimensions<br>4020096 /<br>4020211 | Length 77 mm / 3"<br>Width 70 mm / 2,7"<br>Height 80 mm / 3,2"<br>+ 245 mm / 10" cable with connector |
| Dimensions<br>4020095 /<br>4020210 | Length 95 mm / 4"<br>Width 80 mm / 3,2"<br>Height 100 mm / 3,9"                                       |
| Operating media                    | 30 V / 12 V   |

# ProKASRO UV-Technology

## KASRO UV packer set DN 150 - 500 / 6" - 20"



Article number: 4020224

- with the help of UV packers the inliners are integrated and inflated
- packers are separately available in 5 x 2 different sizes for DN 150 - 500 / 6" - 20"
- appropriate air couplings to connect a blower or compressor hose are on the packers
- the divided Venturi nozzle is in the removable cap of the packer, through which the curing cable is pulled during the rehabilitation
- Packer set DN500 with mount for camera for observation the positioning of the UV light source core
- NEW: compatible with all KASRO UV systems

Optional:

- packer camera

| Technical Data             |   |
|----------------------------|---|
| Packer DN 150<br>6"        | 125 mm / 5" outer diameter<br>length without connections<br>360 mm / 14"  |
| Packer DN 200<br>8"        | 165 mm / 6" outer diameter<br>length without connections<br>360 mm / 14"  |
| Packer DN 300<br>12"       | 260 mm / 10" outer diameter<br>length without connections<br>275 mm / 11" |
| Packer DN 400<br>16"       | 340 mm / 13" outer diameter<br>length without connections<br>275 mm / 11" |
| Packer DN 500<br>20"       | 405 mm / 16" outer diameter<br>length without connections<br>310 mm / 12" |
| Total weight<br>packer set | ca. 130 kg / 287 lbs.   |
| Air connections            | B75, 3/4"-jaw clutch, NW<br>7,2 for pressure control                      |

## KASRO UV packer set DN 600 - 800 / 24" - 32" / DN 1000 / 39"



Article number: 4020225

- with the help of UV packers the inliners are integrated and inflated
- packers are separately available in 2 x 2 different sizes for DN 600 - 800 / 24" - 32"
- appropriate air couplings to connect a blower or compressor hose are on the packers
- the divided Venturi nozzle is in the removable cap of the packer, through which the curing cable is pulled during the rehabilitation
- packers are separable to make the installation in the manhole easier
- with mount for camera for observing the positioning of the UV light source core
- NEW: compatible with all KASRO UV systems

Optional:

- packer camera
- packer set DN 1000 / 39" (Article number: 4020109)

| Technical Data                 |   |
|--------------------------------|---|
| Dimensions for<br>DN 600 / 24" | 475 mm / 19" outer diameter<br>length without connections<br>275mm / 315 mm (11" / 13") |
| Weight                         | 22,5 kg / piece (50 lbs.)   |
| Dimensions for<br>DN 800 / 32" | 620 mm / 25" outer diameter<br>length without connections<br>310 mm / 12"               |
| Weight                         | 36 kg / peace (79 lbs.)   |
| Packer DN 1000<br>39"          | 820 mm / 32" outer diameter<br>length without connections<br>380 mm / 15"               |
| Weight                         | 70 kg / piece (154 lbs.)  |
| Air connections                | B75, 3/4"-jaw clutch, NW 7,2<br>for pressure control                                    |



## KASRO UV packer set DN 1200 - 1600 / 48" - 63"



Article number: 4020257 / 4020258

- with the help of UV packers the inliners are integrated and inflated
- the packer set consists of 2 packers
- appropriate air couplings to connect a blower or compressor hose are on the packers
- the divided Venturi nozzle is in the removable cap of the packer, through which the curing cable is pulled during the rehabilitation
- Packer DN 1600 / 63" with integrated cable routing
- packers are separable to make the installation in the manhole easier
- NEW: compatible with all KASRO UV systems

Optional:

- packer camera

| Technical Data       |   |
|----------------------|---|
| Packer DN1200<br>47" | 900 mm / 35" outer diameter<br>length without connections<br>380 mm / 15"     |
| Weight               | 84,5 kg / piece (186 lbs.)  |
| Packer DN1600<br>63" | 1260 mm / 47" outer diameter,<br>length without cable routing 350<br>mm / 14" |
| Weight               | 106 kg / piece (234 lbs.)   |
| Air connections      | B75, 3/4"-jaw clutch, NW7,2 for<br>pressure control                           |

## KASRO UV packer set oval profile DN 400 / 600 - 1200 / 1800 16" / 24" - 47" / 71"



Article number: 4020105 / 4020106 / 4020107 /  
4020062 / 4020108 / 4020110

- with the help of UV packers the inliners are integrated and inflated
- the packer set consists of 2 packers
- appropriate air couplings to connect a blower or compressor hose are on the packers
- the divided Venturi nozzle is in the removable cap of the packer, through which the curing cable is pulled during the rehabilitation
- NEW: compatible with all KASRO UV systems

| Technical Data                     |  |
|------------------------------------|--|
| Packer 16" - 24"<br>DN 400 / 600   | 360 mm / 14" width, 527 mm /<br>21" height, length 360 mm/ 14" |
| Weight                             | 22,5 kg / piece (50 lbs.)                                      |
| Packer 20" - 30"<br>DN 500 / 750   | 420 mm / 17" width, 660 mm /<br>26" height, length 360 mm/ 14" |
| Weight                             | 28,5 kg / piece (63 lbs.)                                      |
| Packer 24" - 35"<br>DN 600 / 900   | 520 mm / 21" width, 800 mm /<br>32" height, 360 mm/ 14" length |
| Weight                             | 41 kg / piece (90 lbs.)  |
| Packer 32" - 48"<br>DN 800 / 1200  | 710 mm / 28" width, 1060 mm<br>/ 41" height, length 400 mm/16" |
| Weight                             | 85 kg / piece (187 lbs.)                                       |
| Packer 35" - 53"<br>DN 900 / 1350  | 850 mm / 33" width, 1110 mm<br>/ 43" height, length 410 mm/16" |
| Weight                             | 95 kg / piece (209 lbs.)                                       |
| Packer 48" - 71"<br>DN 1200 / 1800 | 1080 mm/42" width, 1410 mm/<br>55" height, length 410 mm/ 16"  |
| Weight                             | 140 kg / piece (309 lbs.)                                      |
| Air connections                    | B75, 3/4"-jaw clutch, NW7,2<br>for pressure control            |

# ProKASRO UV-Technology POWER

## KASRO UV Packer set DN 1800-2000 / 71" - 80"



Article number: 4020259

- with the help of UV packers the inliners are integrated and inflated
- the packer set consists of 2 packers
- appropriate air couplings to connect a blower or compressor hose are on the packers
- the divided Venturi nozzle is in the removable cap of the packer, through which the curing cable is pulled during the rehabilitation
- packers are separable to make the installation in the manhole easier
- including Venturi nozzles diameter 20 mm and 25 mm
- with mount for camera to observe the installation position
- NEW: compatible with all KASRO UV systems

### Optional:

- packer camera

| Technical Data                      |  |
|-------------------------------------|--|
| Packer DN 1800<br>DN 2000 / 70"-80" | 1560 mm / 62" outer diameter<br>length without connections<br>415 mm / 16" |
| Weight                              | ca. 210 kg / piece (463 lbs.)  |
| Air connections                     | B 75, 3/4"-jaw clutch,<br>NW 7,2 for pressure control                      |

## Adapter for KASRO POWER UV light sources



Article number: 4020222 / 4020220

- Adapter for all KASRO POWER UV light sources (18 x 1000/2000W technology) for operation with KASRO UV CCU systems (8 x 1000 W technology) (4020222) and for operation with 12 x 1000 W PROFESSIONAL units (4020220)

| Technical Data |  |
|----------------|--|
| Dimensions     | Length 166 mm / 7"<br>Width 108 mm / 4"<br>Height 84 mm / 3" |
| Weight         | 1,5 kg / 3 lbs.  |

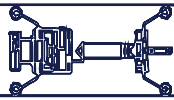

## KASRO POWER UV control unit

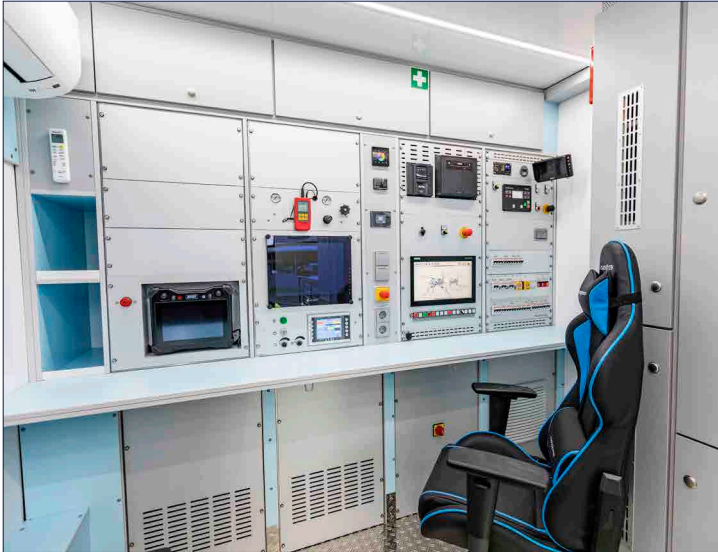

Article number: 4020200

- KASRO POWER UV control 18 x 1000 W / 2000W including control software integrated in the vehicle with the following equipment:
- WIN TV for recording video files including PC
- Another PC with USB and printer
- Video monitor and camera control
- Data acquisition per 3 x liner surface temperature, 1 x air temperature, 1 x calibration pressure
- Fault indication and logging
- 8 x 400 W/ 600 W power supplies and 12 x 1000 W / 2000 W and 18 x 1000 W / 2000 W power supplies
- Hour meter for each UV lamp
- Current measurement and display of each UV lamp for power monitoring
- Includes device for remote maintenance via remote access
- Generator power of at least 100 kVA required

| Technical Data          |   |
|-------------------------|---|
| Dimensions control unit | Length 2240 mm / 94"<br>Wdth 870 mm / 34"<br>Height 1900 mm / 75" |
| Weight                  | 250 kg / 551 lbs.   |
| Operation voltage       | 400 V / 50 Hz / 32 A  |

## KASRO POWER UV curing drum



Article number: 4020201

- KASRO POWER UV cable drum 18 x 1000 W / 2000 W including 200 m / 656' curing cable and cooling system.
- Controlled speed 0,1-5 m/min speed 0,1 - 4 m/min with included PLC Panel
- The electric drive is frequency controlled and monitored by the industrial PC System.
- Must be used only in combination with KASRO POWER UV control unit 18 x 1000 W / 2000 W

| Technical Data  |   |
|-----------------|---|
| Dimensions      | Length 1750 mm / 69" with swivel arm<br>Width 675 mm / 27"<br>Height 1300 mm / 51"                              |
| Weight          | 650 kg / 1433 lbs.  |
| Operating media | 400 V/ 50 Hz  |
| Curing cable    | UV and heat resistant self netting PUR outer sheath, Kevlar reinforced, Teflon isolated, 38x1,5 mm <sup>2</sup> |

# ProKASRO UV Manhole Rehabilitation

## KASRO UV manhole rehabilitation unit



Article number: 4020370-71/ 4020073

### Consisting of:

- UV control box incl. recording, temperature measurement and pressure measurement (4020370)
- UV light source core 4 x 1000 W incl. camera, two temperature sensors and 4 x 1000 W light bulbs (4020371)
- Cable traction unit for KASRO shaft rehabilitation unit (4020073)
- 25 m / 82" curing cable

| Technical Data control box  |   |
|-----------------------------|---|
| Dimensions                  | Width 740 mm / 30"<br>Height 590 mm / 24"<br>Depth 590 mm / 24" |
| Weight                      | 62 kg / 137 lbs.  |
| Voltage                     | 400 V / 50 Hz /16A  |
| Technical Data light source |   |
| Voltage                     | 4 x 1000 W  |
| Diameter                    | 362 mm / 15"  |
| Length                      | 456 mm / 18"  |
| Weight                      | 7,5 kg / 17 lbs.  |

## KASRO UV manhole rehabilitation Packer DN 500 / 20"



Article number: 4020376

- Single packer DN 500 / 20" with lugs for crane suspension and two Venturi nozzles
- with the help of UV packers the inliners are integrated and inflated
- appropriate air couplings to connect a compactor or compressor hose are on the packers
- the divided Venturi nozzle is in the removable cap of the packer, through which the curing cable is pulled during the rehabilitation
- packers are separable to make the installation in the manhole easier
- with monitoring windows and lighting
- with camera device and additional air connections

### Optional:

- packer camera

| Technical Data              |  |
|-----------------------------|--|
| Dimensions for DN 500 / 20" | 380 mm / 15" outer diameter<br>length without connections<br>290mm / 11"                           |
| Weight                      | ca. 15 kg / piece (33 lbs.)  |
| Air connections             | Fixed coupling Storz B-75,G2<br>1/2" AG, rotatable<br>Coupling socket AG 1/2" DN7.2;<br>KD7.2-1/2A |

## KASRO UV manhole rehabilitation Packer DN 600 / 24"



Article number: 4020375

- Single packer DN 600 / 24" with lugs for crane suspension and two Venturi nozzles
- with the help of UV packers the inliners are integrated and inflated
- appropriate air couplings to connect a compactor or compressor hose are on the packers
- the divided Venturi nozzle is in the removable cap of the packer, through which the curing cable is pulled during the rehabilitation
- packers are separable to make the installation in the manhole easier
- with monitoring windows and lighting
- with camera device and additional air connections

Optional:

- packer camera

| Technical Data              |  |
|-----------------------------|--|
| Dimensions for DN 600 / 24" | 470 mm / 15" outer diameter<br>length without connections<br>290mm / 18"                           |
| Weight                      | ca. 25 kg / piece (55 lbs.)  |
| Air connections             | Fixed coupling Storz B-75,G2<br>1/2" AG, rotatable<br>Coupling socket AG 1/2" DN7.2;<br>KD7.2-1/2A |

The rehabilitation of house connections is always a big challenge for sewer rehabilitation companies. In many cases jobsite access is situated in hard to reach areas, such as cellars and backyards.

The bend capable KASRO UV light source chain system Ikarus for diameters from DN 100 - 200 to cure UV house connection liners is predestined for such tasks.



ProKASRO bend capable



# ProKASRO bend capable

## KASRO UV light source chain system IKARUS



Article number: 2025014

- bend capable
- Light chain PLUGABLE 3 x 200 W DN100 - DN150 / 4" - 6"
- Light chain PLUGABLE 1 x 200 W DN100 - DN150 / 4" - 6"
- With 40m / 131' push cable with reel with slip ring and camera **WITH rotary transmitter for unwinding**
- UV control unit with data logging, video recorder and cable traction unit (additional laptop is required to visualize and back up the data)
- Two sensors measure the reaction temperature of the resin and the air temperature inside the liner
- Protocol: Air pressure inside the liner, throughput speed, lamp function, video picture

| Technical Data    |  |
|-------------------|--|
| Dimensions        | Total length 40 m / 131',<br>Diameter DN 100-150 / 4" - 6"; 70 mm / 3"<br>Diameter DN 150-200 / 6" - 8"; 105 mm / 4" |
| Weight            | 30 kg / 66 lbs.  |
| Performance       | 3 x 200 W; 1 x 200 W UV-lamps  |
| Bend capabilities | For bends up to 90°  |
| Equipment         | Feed unit, control unit  |

Article number: 2025015

- Extension kit for KASRO UV light source IKARUS from DN150 to DN 200 / 6" - 8" (3 x 200 W and 1 x 200 W)

| Technical Data control unit |  |
|-----------------------------|--|
| Dimensions                  | Length: 525 mm / 121"<br>Width: 400 mm / 16"<br>Height: 540 mm / 22" |
| Weight                      | 30 kg / 66 lbs.  |



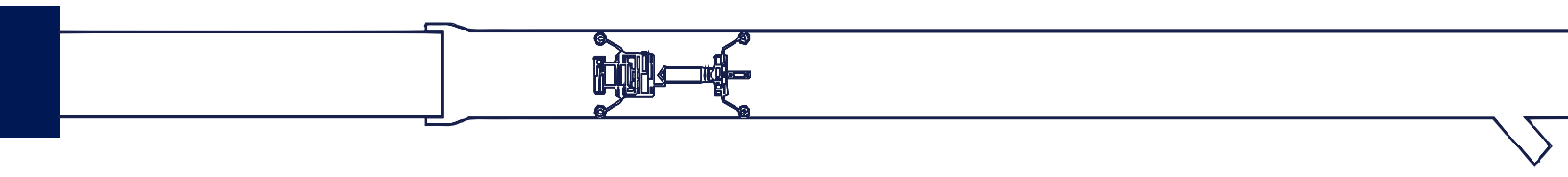

# ProKASRO Rehabilitation Vehicles

3.5t rehabilitation vehicle for KASRO electric working robots with battery pack



Article number: 8001030 / 8001035

**Advantage: can be driven with a normal driver's license and no noise or gas pollution for the environment**

- rehabilitation can be operated within the narrowest streets
- power supply via battery packs with inverter, charging of batteries via a second alternator
- cost-efficient version of a robot rehabilitation vehicle
- DN 150 - 600 / 6" - 24", optional: carriage up to DN 800 / 32", oval profiles
- additional feature: KASRO robots and cameras with pressure

| Technical Data       |   |
|----------------------|---|
| Vehicle              | Self-propelled working machine  |
| Dimensions vehicle   | Length 5787 mm / 228", Width 1933 mm / 76", Height 2750 mm / 108" (for example: Sprinter) |
| Dimensions box       | Length 3311 mm / 130", Width 1780 mm / 70", Height 1840 mm / 73" (for example: Sprinter)  |
| Total weight         | 3490 kg   |
| Power generator      | inverter 5 kW   |
| Water tank           | 160 l   |
| Vehicle not included |   |

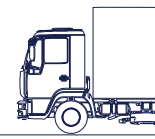

## 5t rehabilitation vehicle for KASRO electric working robots with pull-out generator

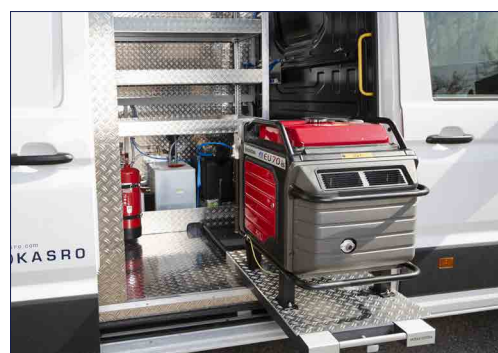
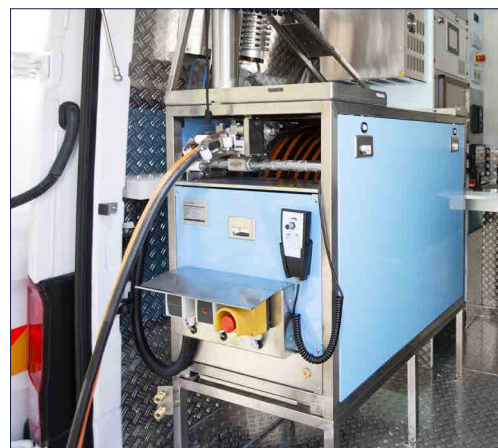

Article number: 8001031

### **Advantage: direct contact with the second man on the construction site and the manhole**

- generously designed storage space and storage space
- no noise in the vehicle due to pull-out platform for generator
- rehabilitation can be operated within the narrowest streets
- cost-efficient version of a robot rehabilitation vehicle
- DN 150 - 600 / 6" - 24", optional: carriage up to DN 800 / 32", oval profiles
- additional feature: KASRO robots and cameras with pressure

| Technical Data       |   |
|----------------------|---|
| Vehicle              | Self-propelled working machine  |
| Dimensions vehicle   | Length 5986 mm / 236", Width 1933 mm / 76", Height 2750 mm / 108" (for example: Sprinter) |
| Dimensions box       | Length 3200 mm / 126", Width 1760 mm / 69", Height 1861 mm / 74" (for example: Sprinter)  |
| Total weight         | 5000 kg   |
| Power generator      | inverter 7 kW   |
| Water tank           | 170 l   |
| Vehicle not included |   |

# ProKASRO Rehabilitation Vehicles

5t rehabilitation vehicle for KASRO electric working robots with accompanying trailer



Artikelnummer: 8001039

**Advantage: Small, compact and flexible solution for a rehabilitation unit. In addition, a C1 driving license is sufficient**

- rehabilitation can be operated within the narrowest streets
- Sprinter and trailer are each powered by a battery pack
- batteries are charged via the second alternator or StageV generator in the trailer with feed-in to the vehicle
- Trailer for additional storage space, work space and additional energy supply
- cost-efficient version of a robot rehabilitation vehicle
- DN 150 - 600 / 6" - 24", optional: carriage up to DN 800 / 32", oval profiles
- additional feature: KASRO robots and cameras with pressure

| Technical Data       |  |
|----------------------|--|
| Vehicle              | Self-propelled working machine   |
| Dimensions vehicle   | Length 6967 mm / 274", Width 2427 mm / 96", Height 2285 mm / 90" (for example: Sprinter) |
| Dimensions box       | Length 4307 mm / 170", Width 1760 mm / 70", Height 1861 mm / 74" (for example: Sprinter) |
| Total weight         | 5000 kg  |
| Power generator      | inverter 5 kW  |
| Water tank           | 160 l  |
| Vehicle not included |  |

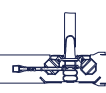
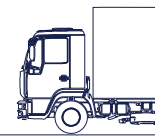

## 6 t SUPERIOR rehabilitation vehicle with HYBRID drive for KASRO electric robots



Artikelnummer: 8001050

### Highlights:

- Hybrid DC charging generator 12kW with autostart
- 900Ah GEL-Deep Cycle batteries
- 7kW inverter (peak 15kW)
- 10" touch display
- Can-Bus cabling for remote maintenance
- deep discharge protection
- DN 150 - 600 / 6" - 24", optional: carriage up to DN 800 / 32", oval profiles
- additional feature: KASRO robots and cameras with pressure

| Technical Data       |  |
|----------------------|--|
| Vehicle              | Self-propelled working machine   |
| Dimensions vehicle   | Length 7128 mm / 280", Width 2052 mm / 80", Height 2780 mm / 110" (for example: Iveco) |
| Dimensions box       | Length 4680 mm / 185", Width 1740 mm / 69", Height 1900 mm / 75" (for example: Iveco)  |
| Total weight         | 6000 kg  |
| Power generator      | inverter 7 kW  |
| Water tank           | 170 l  |
| Vehicle not included |  |

# ProKASRO Rehabilitation Vehicles

## 14 - 18t EXPERT rehabilitation vehicle for KASRO UV PROFESSIONAL

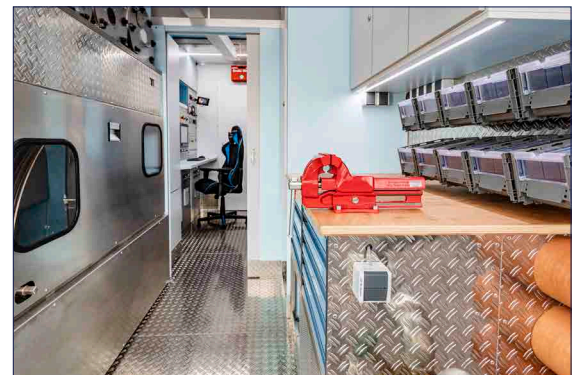
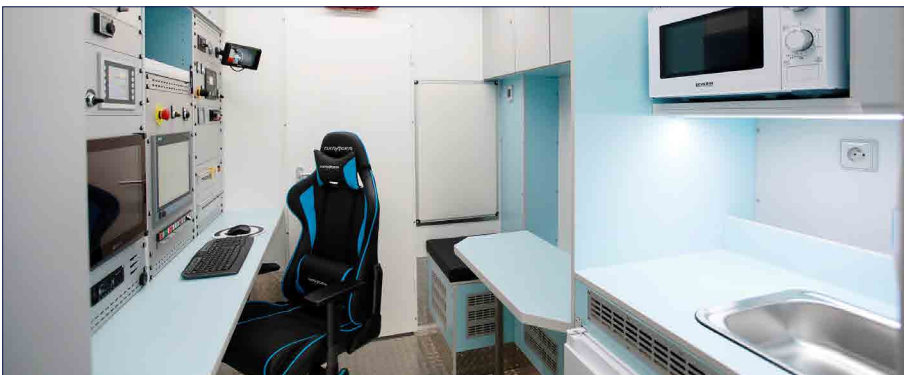

Article number: 8004053

- **Overall rehabilitation with UV-Technology gets possible!**  
operation of all KASRO UV light source chains and cores from 8 x 400/600 W up to 12 x 1000 W for the diameters DN 150 to DN 1600 / 6" - 63"
- Surcharge for body box paintwork in your favourite colour (Article number: 7027011)
- Installed equipment: customised built-in cupboards, seats with desk, work bench incl. tools, control panel, water tank with pump, lamps, sockets, air conditioner and battery buffered auxiliary heater
- kitchen with refrigerator, microwave, wash basin (available separately)
- Power generator and air blower are available separately (depends on the rehabilitation equipment) are installed in a separate machine room (directly behind the cab), accessible through 2 doors left and right

| Technical Data (Vehicle not supplied) |   |
|---------------------------------------|---|
| Vehicle                               | Self-propelled working machine  |
| Dimensions Container                  | Length 7000 mm / 275", Width 2480 mm / 97", Height 2300 mm / 91" (varies) |
| Power generator                       | 45 kVA or 80 kVA  |
| Total weight                          | variable weight   |
| Water tank                            | 80-130 l  |
| Air blower                            | 800 mbar / 6m <sup>3</sup> / min or 1100 mbar / 8m <sup>3</sup> / min     |

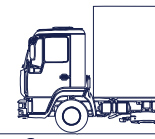

## 14 - 18t EXPERT rehabilitation vehicle for KASRO UV CCU



Article number: 8004053

- **Overall rehabilitation with UV-Technology gets possible!**  
operation of all KASRO UV light source chains and cores from 8 x 400/600 W up to 8 x 1000 W for the diameters DN 150 to DN 1600 / 6" - 63"
- with removable CCU
- Installed equipment: customised built-in cupboards, seats with desk, work bench incl. tools, control panel, water tank with pump, lamps, sockets, air conditioner and battery buffered auxiliary heater
- kitchen with refrigerator, microwave, wash basin (available separately)
- Power generator and air blower are available separately are installed in a separate machine room (directly behind the cab), accessible through 2 doors left and right

| Technical Data (Vehicle not supplied) |   |
|---------------------------------------|---|
| Vehicle                               | Self-propelled working machine  |
| Dimensions Container                  | Length 6500 mm / 256", Width 2480 mm / 97", Height 2150 mm / 85" (varies) |
| Power generator                       | 40 kVA  |
| Total weight                          | variable weight   |
| Water tank                            | 80-130 l  |
| Air compressor                        | 800 mbar / 6 m <sup>3</sup> / min   |

# ProKASRO Rehabilitation Vehicles

## 14 - 18t EXPERT rehabilitation vehicle for KASRO POWER UV Technology



Article number: 8004053

- **Overall rehabilitation with UV-Technology gets possible!**

operation of all KASRO POWER UV light source chains and cores from 9 x 400/600 W up to 18 x 1000 W / 2000W and 4 x 4 x 1000 W / 2000 W for the diameters DN 150 to DN 2000 / 6" - 80"

- Surcharge for body box paintwork in your favourite colour (Article number: 7027011)
- Installed equipment: customised built-in cupboards, seats with desk, work bench incl. tools, control panel, water tank with pump, lamps, sockets, air conditioner and battery buffered auxiliary heater
- kitchen with refrigerator, microwave, wash basin (available separately)
- Power generator and air blower are available separately (depends on the rehabilitation equipment) are installed in a separate machine room (directly behind the cab), accessible through 2 doors left and right

### Technical Data (Vehicle not supplied)

|                      |   |
|----------------------|---|
| Vehicle              | Self-propelled working machine  |
| Dimensions Container | Length 7000 mm / 275", Width 2480 mm / 97", Height 2300 mm / 91" (varies) |
| Power generator      | ≥ 100 kVA   |
| Total weight         | variable weight   |
| Water tank           | 80-130 l optional   |
| Air blower           | ≥ 1100 mbar / 8m <sup>3</sup> / min                                       |



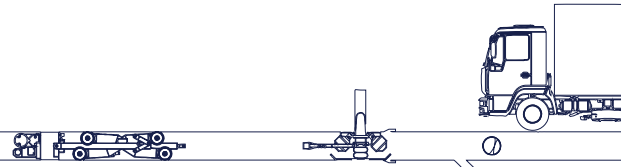

## Components for KASRO POWER UV EXPERT

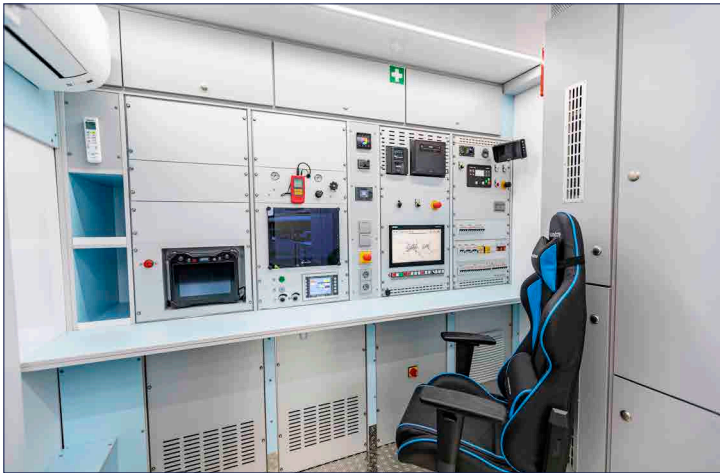

Article number: 4020200



Article number: 4020201



Article number: 4020203

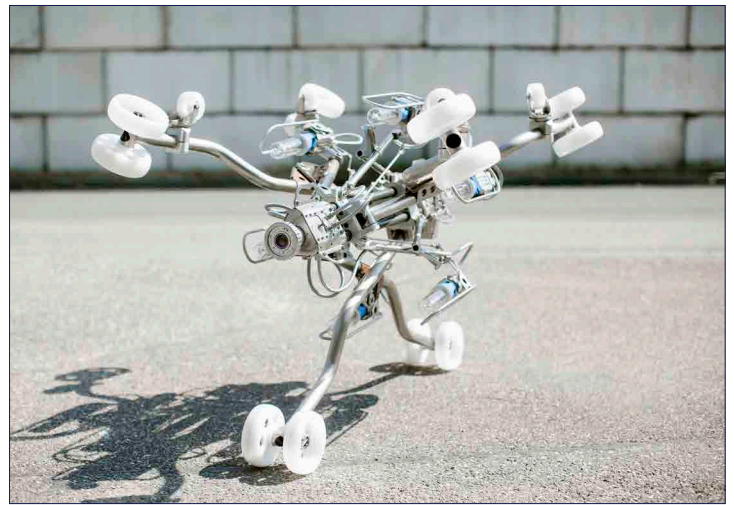

Article number: 4020204

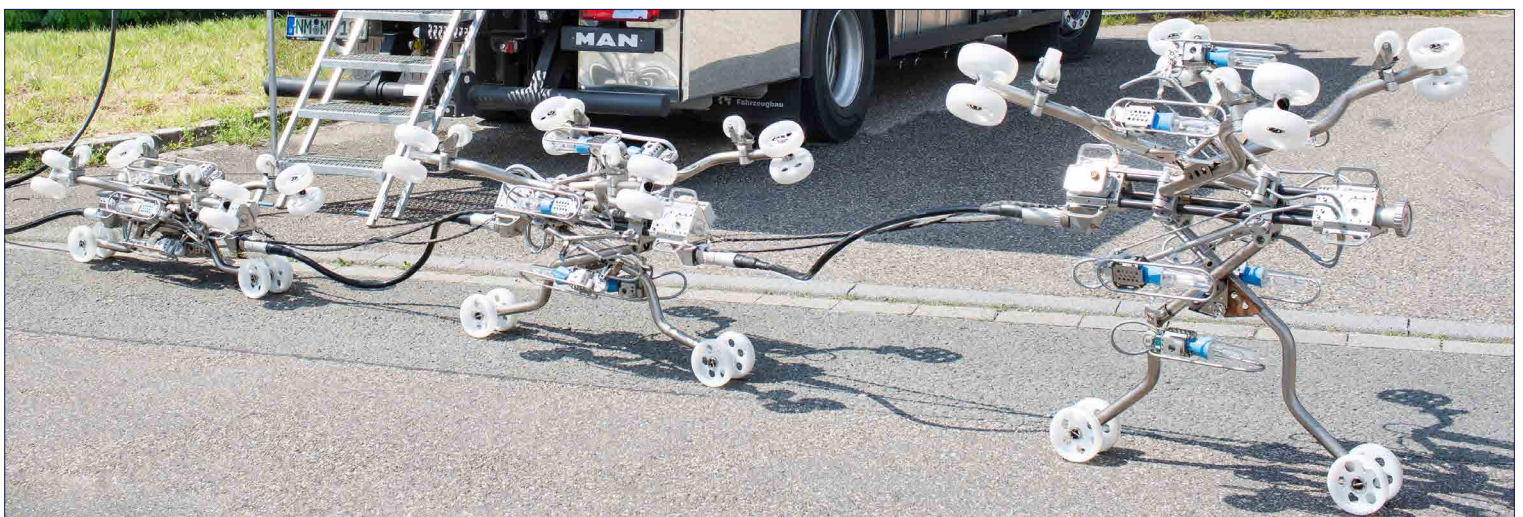

Article number: 4020205

# ProKASRO Rehabilitation Vehicles

12 - 18 t EXPERT rehabilitation vehicle for KASRO electric working robots



Article number 8004066

- **Overall rehabilitation gets possible!**  
operation of ALL electric working robots for milling and ALL systems for lateral intake rehabilitation (for injection, cap placement)
- The installed equipment includes customised built-in cupboards, seats with desk, work bench incl. tools, control panel, water tank with pump, lamps, sockets, air conditioner and battery buffered auxiliary heater
- kitchen with refrigerator, microwave and wash basin (available separately)
- The power supply results by the inverter 3000 VA which is supplied via the battery packs with 1.040 Ah / 12 V and a super-silent Diesel generator 8000 VA (directly behind the cab)
- additional feature: KASRO robots and cameras with pressure

| Technical Data (Vehicle not supplied) |  |
|---------------------------------------|--|
| Vehicle                               | Self-propelled working machine                                   |
| Dimensions Container                  | Length 7000 mm / 275", Width 2480 mm / 97", Height 2150 mm / 85" |
| Power generator                       | 12 kVA   |
| Total weight                          | variable weight  |
| Water tank                            | 190 l  |
| Air compressor                        | 10 bar, 0,3 m <sup>3</sup> /min                                  |

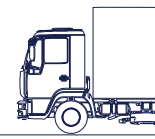

## 12 - 18 t EXPERT rehabilitation vehicle for KASRO pneumatic working robots

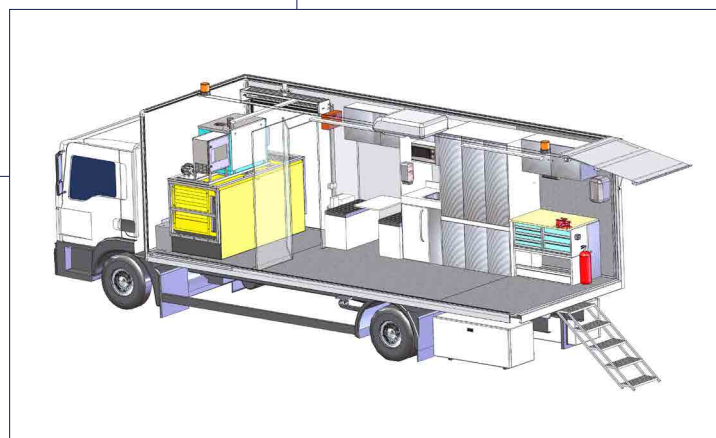
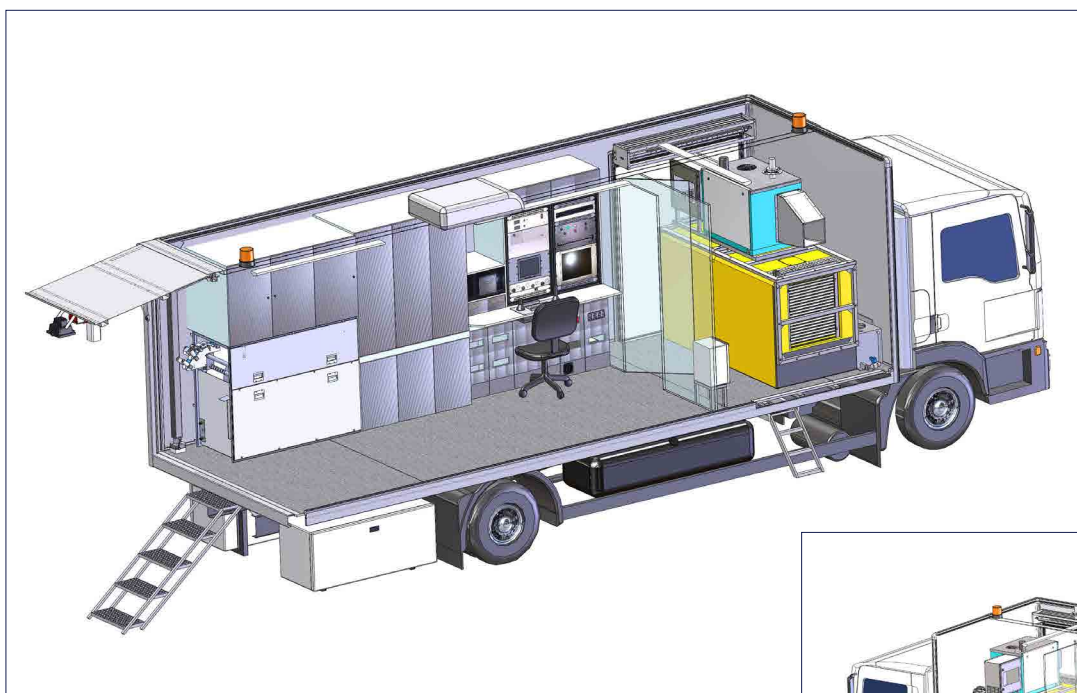

Article number 8004085

- **Overall rehabilitation gets possible!**

operation of ALL pneumatic working robots (for milling, filling) and ALL systems for lateral intake rehabilitation (for injection, cap placement)

Installed equipment: custom-made cupboards, seat bench with table and swivel chair, operator station, work bench including high quality set of tools, water tank with pump, fuel tank with fuel indicator, air conditioning, battery-buffered auxiliary heating, lamps, sockets, cooling box, basic equipment

- kitchen with refrigerator, microwave and wash basin (available separately)
- preparation for the installation of a generator, batteries and compressor in a separate machine room incl. rain flap and retractable stairs with an unilateral handrail to enter at the rear of the vehicle
- additional feature: KASRO robots and cameras with pressure

| Technical Data (Vehicle not supplied) |  |
|---------------------------------------|--|
| Vehicle                               | Self-propelled working machine                                   |
| Dimensions Container                  | Length 7000 mm / 275", Width 2480 mm / 97", Height 2150 mm / 85" |
| Power generator                       | 30 kVA   |
| Total weight                          | variable weight  |
| Water tank                            | 190 l  |
| Air compressor                        | 10 bar, 2,5 m <sup>3</sup> /min                                  |

# ProKASRO Rehabilitation Vehicles

5t rehabilitation vehicle for KASRO hydraulic working robots with trailer



Article number: 8001045

## Hydraulic working robots in a 5t vehicle with trailer for spatula works

- rehabilitation can be operated within the narrowest streets
- cost-efficient version of a robot rehabilitation vehicle
- DN 150 - 600 / 6" - 24", optional: carriage up to DN 800 / 32", oval profiles
- installed equipment within the trailer: conditioning cabinet, generator, work bench, mixing machine

| Technical Data       |   |
|----------------------|---|
| Vehicle              | Self-propelled working machine  |
| Dimensions vehicle   | Length 7345 mm / 289", Width 1993 mm / 76", Height 3055 mm / 120" (for example: Sprinter) |
| Dimensions box       | Length 4700 mm / 185", Width 1780 mm / 70", Height 1940 mm / 77" (for example: Sprinter)  |
| Dimensions trailer   | Length 3500 mm / 138", Width 2100 mm / 83", Height 2100 mm / 83"                          |
| Total weight         | 5000 kg, trailer: 3490 kg   |
| Power supply         | aggregate within the trailer, hydraulic pump 150 bar, 17 l/min                            |
| Water tank           | 200 l   |
| Vehicle not supplied |   |

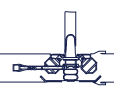
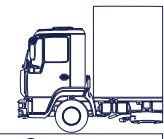

## KASRO 20" Container - Example KASRO UV-Technology



Article number: 8004052

- **Optimal Solution for the international deployment!**

Ready-to-connect system internationally normed: transportable via any ship or truck

- Equipment according to individual application: all applications can be installed
- Power generator is installed in a separate machine room accessible through 2 roller doors left and right
- Container 20" with CSC admission

| Technical Data   |  |
|--|--|
| Vehicle  | Self-propelled work machine                                      |
| Dimensions Container   | Length 5890 mm / 232", Width 2350 mm / 93", Height 2372 mm / 94" |
| Power generator  | 40 - 65 kVA  |
| Water tank   | 95 l   |
| This container (exemplary) was built after individual customer requests. |  |

# ProKASRO Rehabilitation Vehicles

14 - 18 t EXPERT 2.0 rehabilitation vehicle for KASRO UV technology



Article number: 8004069

- **Overall rehabilitation gets possible!**

All KASRO UV Technologies can be integrated in this vehicle type

- The installed equipment includes customised built-in cupboards, seats with desk, work bench incl. tools, water tank with pump, lamps, sockets, air conditioner and battery buffered auxiliary heater
- kitchen with refrigerator, microwave and wash basin (optional)
- Power generator and air blower (available separately) are installed in a separate machine room (directly behind the cab), accessible through 2 doors left and right
- Rain cover can be pushed out pneumatically or electrically
- Lateral ladder for an easy access to the machine room (firmly attached)
- two drawers for optimal storage the UV light sources
- Battery Pack 520 AH / 24 V (optional)

| Technical Data (Vehicle not supplied) |  |
|---------------------------------------|--|
| Vehicle                               | Self-propelled work machine                                      |
| Dimensions Container                  | Length 7045 mm / 277", Width 2445 mm / 96", Height 2243 mm / 88" |
| Power generator                       | 60 kVA   |
| Total weight                          | variable weight  |
| Water tank                            | 80 - 130 l   |
| Blower                                | DTLF 2.500; 18,5 Kw; 1,1 bar, 8m <sup>3</sup> /min               |

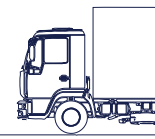

## 12 - 18 t HYBRID rehabilitation vehicle for KASRO electric working robots for all functions



Article number: 8004068

- **Highlight: 16 hours battery life**
- Self-sufficient operation of the system via battery pack
- the solar system charges the batteries, even during operation
- Direct charge of the batteries by direct current from the compact and whisper-quiet DC generator
- roller shutter doors can be operated electrically and by remote control
- Fully automatic rain flap
- Ambient lighting by 5 LED light strips, additionally switchable via remote control
- firmly integrated entry steps

Technical Data reserved

Images are examples - contain partly more than the scope of delivery

| Technical Data (Vehicle not supplied) |   |
|---------------------------------------|---|
| Vehicle                               | Self-propelled work machine   |
| Dimensions Container                  | Length 7045 mm / 277", Width 2445 mm / 96", Height 2243 mm / 88"                    |
| Power generator                       | DC-Generator System Whisper Power (3-Zylinder Kubota D722, 10 KVA 300 A /28,4 Volt) |
| Total weight                          | variable weight   |
| Solar system                          | 1710 W  |
| Water tank                            | 80-130 l  |
| Battery Pack                          | 19800Ah   |



**ProKASRO Mechatronik GmbH**

Im Schlebert 6  
D-76187 Karlsruhe  
Telefon +49 721 95082-0  
Telefax +49 721 95082-28  
info@prokasro.de  
www.prokasro.de

